

MSP430™ Ultra-Low-Power Microcontrollers



MSP430™ Microcontrollers

MSP430 Microcontrollers (MCUs) from Texas Instruments (TI) are 16-bit, RISC-based, mixed-signal processors designed specifically for ultra-low-power. MSP430 MCUs have the right mix of intelligent peripherals, ease-of-use, low cost and lowest power consumption for thousands of applications – including yours. TI offers robust design support for the MSP430 MCU platform along with technical documents, training, tools and software to help designers develop products and release them to market faster. Learn more at www.ti.com/msp430.



MSP430 Microcontroller DNA

Ultra-Low Power

The MSP430 MCU is designed specifically for ultra-low-power applications. Its flexible clocking system, multiple low-power modes, instant wakeup and intelligent autonomous peripherals enable true ultra-low-power optimization, dramatically extending battery life.

Flexible Clocking System – The MSP430 MCU clock system has the ability to enable and disable various clocks and oscillators which allow the device to enter various low-power modes (LPMs). The flexible clocking system optimizes overall current consumption by only enabling the required clocks when appropriate.

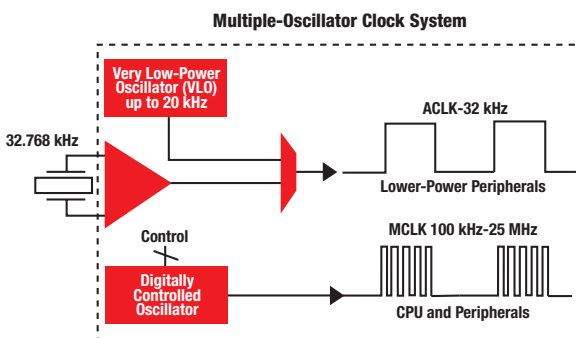

Main Clock (MCLK) – CPU source that may be driven by the internal Digitally Controlled Oscillator (DCO) up to 25 MHz or with external crystal.

Auxiliary Clock (ACLK) – Source for individual peripheral modules driven by the internal low-power oscillator or external crystal.

Key Features

- Ultra-low-power (ULP) architecture and flexible clock system extend battery life: 0.1- μ A RAM retention, <1- μ A RTC mode, <100 μ A MHz
- Integrated intelligent peripherals including a wide range of high-performance analog and digital peripherals that off-load the CPU
- Easy-to-use 16-bit RISC CPU architecture enables new applications with industry-leading code density
- Complete development ecosystem with tools starting at \$4.30
- Enhanced libraries to benefit several applications such as capacitive touch, metering metrology, low power design and debugging

450+ Ultra-Low-Power Devices

8-MHz to 25-MHz CPU Speed
0.5KB to 512KB Flash
128B to 64KB RAM
14 to 113 pins; 25+ packages

Sub-Main Clock (SMCLK) – Source for faster individual peripheral modules that may be driven by the internal DCO up to 25 MHz or with external crystal.

Instant Wakeup – The MSP430 MCU can wake-up instantly from LPMs. This ultra-fast wake-up is enabled by the MSP430 MCU's internal digitally controlled oscillator (DCO), which can source up to 25 MHz and be active and stable in 1 μ s. Instant wake-up functionality is important in ultra-low-power applications since it allows the microcontroller to use the CPU in very efficient bursts and spend more time in LPMs.

Zero-Power Brown-Out Reset (BOR) – The MSP430 MCU's BOR is always enabled and active in all modes of operation. This ensures the most reliable performance possible while maintaining ultra-low-power consumption. The BOR circuit detects low supply voltages and resets the device when power is applied or removed. This functionality is especially critical in battery-powered applications.

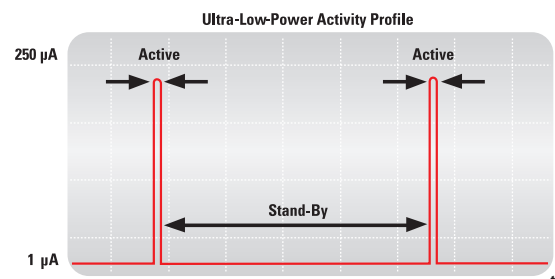

Ultra-fast 1- μ s DCO start-up allows MSP430-based systems to remain in low-power modes for the longest possible interval – extending battery life. The DCO is fully user programmable.

MSP430™ Microcontroller DNA

Highly Integrated

MSP430 MCUs are highly integrated and offer a wide range of high-performance analog and digital peripherals.

Intelligent Peripherals

The MSP430 MCUs peripherals have been designed to assure maximum functionality and provide system-level interrupts, resets and bus arbitration at the lowest power. Many peripherals may function autonomously, thereby minimizing CPU time spent in active mode.

High-Performance Integration

The 400+ MSP430 devices offer high-performance integration including USB, RF, LCD controllers and Sigma-Delta ADCs. The scalable portfolio allows designers to find the appropriate MSP430 device for many low-power applications. The MSP430 MCU's high integration also enables solutions with smaller physical footprints and minimizes the overall bill of materials.

Snapshot of Integrated Peripherals

- ADC10
- ADC12
- SD16
- SD24
- Comparator
- DAC12
- DMA
- Multiplier
- OpAmp
- Timers
- Watchdog timer (WDT)
- RTC
- PMM
- Brownout reset (BOR)
- SVS
- RF Front End
- A-POOL
- AES
- USB
- SPI
- I²C
- UART
- LIN/IrDA
- SCAN_IF
- ESP430
- LCD
- Capacitive Touch

Easy to Get Started

MSP430 MCUs are easy-to-use because of a modern 16-bit RISC architecture and a simple development ecosystem.

16-Bit Orthogonal Architecture

The MSP430 MCU's 16-bit architecture provides the flexibility of 16 fully-addressable, single-cycle, 16-bit CPU registers with the power of a RISC. The modern design of the CPU offers versatility using only 27 easy-to-understand instructions and seven consistent addressing modes.

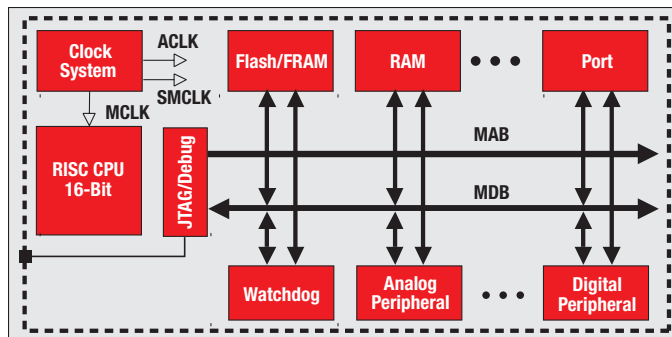

Complete Development Ecosystem

The MSP430 development environment is affordable, seamless and easy-to-use. Get started with the \$4.30 MSP430 Value Line LaunchPad development kit, or use the adaptable MSP-FET430UIF that supports development on all MSP430 devices. Also, download free IDE options such as TI's Code Composer Studio™ IDE, IAR Embedded Workbench or the open-source MSPGCC. MSP430Ware is also available, which is a complete collection of all MSP430 MCU related design resources.

Operating Mode	Description	CPU (MCLK)	SMCLK	ACLK	RAM Retention	BOR	Self Wakeup	Interrupt Sources
Active	CPU, all clocks and peripherals available.	●	●	●	●	●		Timers, ADC, DMA, UART, WDT, I/O, comparator, Ext. Interrupt, RTC, serial communications, other peripherals
LPM0	CPU is shutdown, peripheral clocks available.		●	●	●	●	●	Timers, ADC, DMA, UART, WDT, I/O, comparator, Ext. Interrupt, RTC, serial communications, other peripherals
LPM1	CPU is shutdown, peripheral clocks available. DCO is disabled and the DC generator can be disabled.		●	●	●	●	●	Timers, ADC, DMA, UART, WDT, I/O, comparator, Ext. Interrupt, RTC, serial communications, other peripherals
LPM2	CPU is shutdown, only one peripheral clock available. DC generator is enabled.			●	●	●	●	Timers, ADC, DMA, UART, WDT, I/O, comparator, Ext. Interrupt, RTC, serial communications, other peripherals
LPM3	CPU is shutdown, only one peripheral clock available. DC generator is disabled.			●	●	●	●	Timers, ADC, DMA, UART, WDT, I/O, comparator, Ext. Interrupt, RTC, serial communications, other peripherals
LPM3.5	No RAM retention, RTC can be enabled. (MSP430F5xx generation only)					●	●	Ext. Interrupt, RTC
LPM4	CPU is shutdown and all clocks disabled.				●	●		Ext. Interrupt
LPM4.5	No RAM retention, RTC disabled. (MSP430F5xx generation only)					●		Ext. Interrupt

Why Choose an MSP430™ Microcontroller?

Ultra-Low Power

The MSP430 MCU is designed specifically for ultra-low-power applications. Its flexible clocking system, multiple low-power modes, instant wakeup and intelligent autonomous peripherals enable true ultra-low-power optimization, dramatically extending battery life.



FRAM

TI is always pushing forward with unique new technologies to decrease power consumption and increase ease-of-use. To those ends we introduce Ferroelectric Random Access Memory (FRAM). FRAM is a universal, non-volatile memory that combines the speed, endurance and flexibility of RAM with the stability and reliability of Flash all in one unified section of memory, while decreasing power consumption.

Multiple Package Options

The MSP430 family offers over 25 packages to best fit end-equipment needs and to facilitate manufacturing. For today's increasing need for miniaturization, MSP430 also supports many devices in bare die and die-sized BGA (DSBGA) packages as small as 3x3 mm.

Easy-to-Use Software

The MSP430 family is supported by a complete and easy software development ecosystem. Free software development environments are available from TI's Code Composer Studio™ IDE, IAR Embedded Workbench or the open-source MSPGCC. The brand new MSP430Ware is also available, which is a complete collection of all MSP430-related design resources. MSP430 MCUs also have peripheral configuration tools, easy-to-use APIs and other software tools to get you to market faster.

Low-Cost Options

The new MSP430 Value Line series offers ULP and 16-bit performance for low-cost, lower-end applications. Ideal for high-volume/low-cost designs, these MCUs are priced as low as 25 cents. Start developing on MSP430 Value Line devices using the \$4.30 LaunchPad development kit.

← Ultra-Low Power Performance		— Analog Integration		— Easy-to-Use		→				
MSP430™ 16-bit RISC CPU All devices feature: <ul style="list-style-type: none"> • 16-bit timers • Watchdog timer • Internal Digitally Controlled Oscillator • External crystal support • <50 nA pin leakage • <6 μs wakeup 	L092 0.9V-1.65V Speed: 4 MHz ROM: Up to 2Kb RAM: Up to 2Kb GPIO: 11	BOR DAC8 Comp SVS BOR WDT A-POOL	G2xxx Speed: 16 MHz Flash: 0.5-16Kb RAM: Up to 512b GPIO: 10-24	BOR ADC10 Comp Temp USCI UART Cap sense I/Os	F4xx Speed: 8/16 MHz Flash: 4-120Kb RAM: Up to 8Kb GPIO: 14-80	BOR LCD ADC10,12 SD16 Comp DAC12 DMA MPY OpAmp SVS USART USCI ESP430 SCAN_IF Basic Timer WDT+ RTC	F5xx/6xx Speed: 25 MHz Flash: 8-256Kb RAM: Up to 18Kb GPIO: 32-83	PMM BOR SVS SVM LDO MPY USCI DMA USB ADC10 Comp RTC WDT LCD SD24	CC430 Speed: 20 MHz Flash: 8-16Kb RAM: Up to 4Kb GPIO: 40	PMM BOR SVS SVM LDO MPY USCI DMA Sub 1 GHz RF AES Comp RTC ADC12 LCD
Some Devices	All Devices									

Key Applications

Metering	Portable Medical	Sensor Networks
<p>The MSP430™ MCU's ultra-low power and analog integration are ideal for metering applications. The portfolio offers devices preconfigured to support single- to three-phase electricity metering, while others are integrated with special scan peripherals for flow metering applications.</p> <p>www.ti.com/430metering</p> 	<p>The MSP430 MCUs integrated analog signal chain and ultra-low-power performance is perfect for many medical applications, especially portable measurement devices. Also, the competitive cost of designing with an MSP430 MCU enables availability of care to more people around the world.</p> <p>www.ti.com/430medical</p> 	<p>The speed, flexibility and endurance of new FRAM MSP430 devices with the intelligent analog and flexible clocking of the MSP430 MCU produce an ideal platform for data logging applications like structural monitoring, secure access and building automation.</p> <p>www.ti.com/fram</p> 
Wireless Communications	Capacitive Touch	Personal Health and Fitness
<p>The CC430 is a small, cost-efficient, and performance-rich solution that integrates RF functionality into the MSP430 MCU. This low-power wireless processor is ideal for space and cost-constrained applications such as remote sensing applications.</p> <p>www.ti.com/cc430</p> 	<p>The MSP430 MCU enables capacitive touch interfaces like buttons, wheels or sliders through its on-chip oscillators and Capacitive Touch Sense I/Os without the need for external components. A free Capacitive Touch Software Tool Suite and low cost hardware tools are available to quickly develop an application without needing to understand the underlying theory.</p> <p>www.ti.com/capacitivetouch</p> 	<p>Pairing the MSP430 MCU's small size, ultra-low power and integrated analog with RF functionality enables devices to monitor anything from heart rate, to running speed, to the amount of air in a scuba tank. The eZ430-Chronos™ development system in a watch is available to get you started.</p> <p>www.ti.com/chronos</p> 
Energy Harvesting	Motor Control	Security and Safety
<p>The MSP430 MCU's ultra-low-power consumption and powerful analog and digital interfaces can harvest wasted energy from the environment, making it possible to create self-powered systems that eliminate the need to replace batteries. The eZ430-RF2500-SEH is a complete energy harvesting development kit that is available to get you started.</p> <p>www.ti.com/energyharvesting</p> 	<p>Ti's integrated communication peripherals and high-performance analog make the MSP430 MCU a great choice for controlling stepper, BLDC, and DC motors in applications like printers, fans, antennas and toys.</p> <p>www.ti.com/motorcontrol</p> 	<p>MSP430 MCUs not only have the lowest power consumption to enable the longest lasting critical devices, but they support features for secure applications like JTAG fuses, custom programming, intelligent power supply monitoring, dedicated watchdog timers, LCD, and high-performance analog.</p> <p>www.ti.com/430security</p> 

What's New with MSP430™ Microcontrollers?

FRAM: The future of embedded memory

FRAM, or Ferroelectric Random Access Memory, is a type of non-volatile memory that combines the speed, ultra-low power, endurance, and flexibility of SRAM with the reliability and stability of flash to combine program and data into one unified memory space for the lowest power and easiest to use microcontroller architecture. www.ti.com/fram

Benefits of Embedded FRAM

Lowest Power

- Industry leading active power consumption of $<100\mu\text{A}/\text{MHz}$
- 250x less power than Flash writes
- Protected write completion

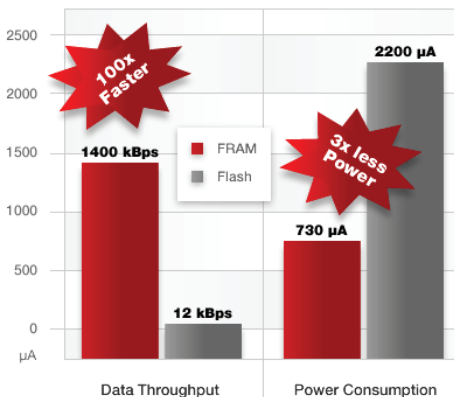

True unified memory

FRAM is the only unified memory in microcontrollers today, that gives developers the flexibility to designate any section of memory as program or data memory. This can be changed throughout the development process to suit the changing needs of the application.

This feature allows faster time to market and simplified inventory management – one single device can be configured into nearly unlimited memory configurations.

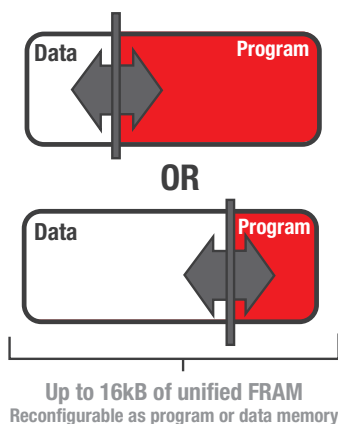

Industry-leading speed

In addition to lower power performance, FRAM can also maintain unmatched data throughput for non-volatile data storage. MSP430 MCUs with embedded FRAM are capable of speeds up to 2 Megabytes/second ensuring that memory is no longer the bottleneck of your application.

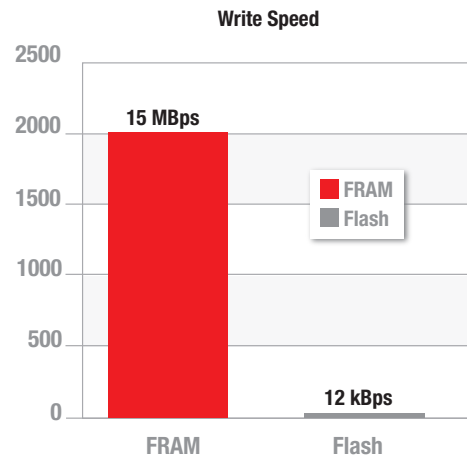

FRAM can write more than 100x faster than flash, while consuming less power!

- FRAM max throughput = 2000kB/s
- Flash max throughput = 12kB/s

Virtually unlimited write endurance

Embedded FRAM also offers longevity and endurance that existing memory technologies cannot match. This increased write endurance is particularly ideal for data logging, digital rights management, replacing battery-backed SRAM and other applications.

- 10^{15} write cycles for FRAM

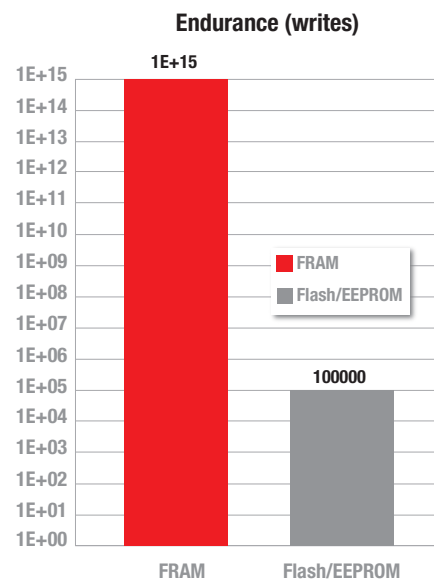

What's New with MSP430™ Microcontrollers?

Ultra-low-power capacitive touch: buttons, sliders, wheels and proximity

Enabling the world's lowest power touch sense capabilities on all MSP430 MCUs, the capacitive touch portfolio includes hardware and free software to give developers easy-to-use, cost effective options for microcontroller-based capacitive touch applications, while still benefitting from the battery-saving features of the MSP430 MCU. www.ti.com/capacitivetouch

MSP430 capacitive touch features:

- Supported by all MSP430 microcontrollers
- Ultra-low-power touch buttons down to 1µA
- Supports buttons, sliders, wheels and proximity sensors
- Free Touch Sense Software Library consuming as little as 1kB
- Cap Sense I/O module available: No external components required

Capacitive Touch Sense Software Library

The royalty-free MSP430 Capacitive Touch Sense Software Library gives developers the option to add touch sense capabilities to any MSP430 microcontroller consuming as little as 1KB of program memory. The open-source software library eliminates the need to develop complex touch sensing algorithms and supports various capacitive touch sensors, including buttons, sliders, wheels and proximity.

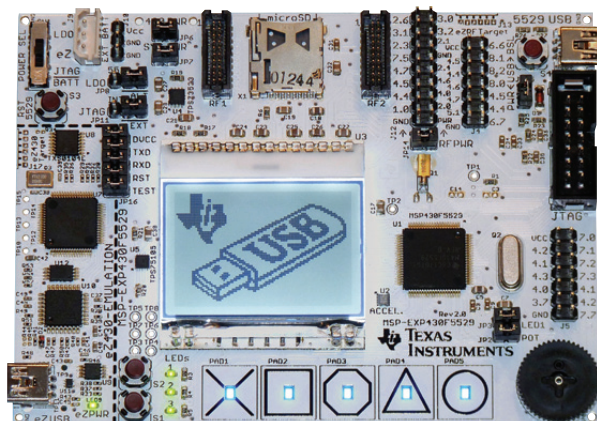

MSP-EXP430F5529 Experimenter Board is a fully featured USB development board with sensors, LCD display and a capacitive touch slider.

Introducing the MSP430 MCU's first high-resolution Timer D

MSP430F51x2 expands the ultra-low-power portfolio with 5V tolerant IOs.

Ideal for capacitive touch, motor control, LED lighting and power management applications, the new MSP430F51x2 series provides two high-precision timers designed for high-precision measurement and control applications, along with 5V tolerant IOs. Each 16-bit precision timer integrates three capture and compare registers and supports high resolution modes running up to 256MHz, equivalent to 4ns resolution.

Timer D also includes a dual capture mode reducing loading of capture operation by half. In addition, the combining compare blocks help to control both rising and falling edges of the PWM output signal. The Timer-Event-Control-block offers external triggering options as well as internal synchronization of timer instances.

www.ti.com/430timer

Key features:

- 4ns resolution at 16MHz input clock for PWM output and capture input
- Low-power consumption: 40µA/MHz
- Full PWM capability combining buffered CCR registers for one channel
- Synchronization of Timer instances
- 100% SW compatible to existing Timer_B

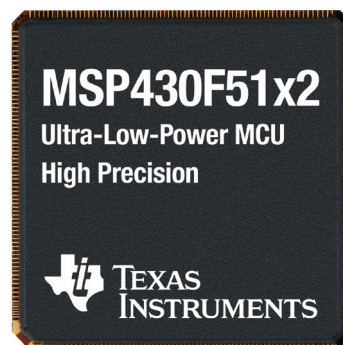

MSP430™ MCU Software Tools

MSP430 is known for providing the world's largest ultra-low-power microcontroller portfolio in the industry or in other words, great hardware. The MSP430 team recognizes that developers also need easy-to-use and powerful software tools to enable high-quality and differentiated applications. The MSP430 software ecosystem can help developers tap into the ultra-low-power performance and intelligent peripherals that are integrated in all 400+ MSP430 devices.

MSP430Ware, featuring Driver Library Everything you need to become an MSP430 MCU expert.

Get the latest and greatest MSP430 MCU design resources in one place.

MSP430Ware is a collection of code examples, datasheets and other design resources for all MSP430 devices delivered in a convenient package; essentially everything you need to become an MSP430 MCU expert.

In addition to providing a complete collection of existing resources, MSP430Ware also includes a brand new high-level API called MSP430 Driver Library. This new library makes it easy to talk to MSP430 hardware. As of today, MSP430 Driver Library supports MSP430F5xx and 6xx devices. Learn more about MSP430Ware at

www.ti.com/msp430ware

Key features:

- MSP430Ware's content is delivered in a sleek, interactive GUI
- Automatic updates make sure you have the latest resources

The MSP430Ware package includes:

- Code Examples
- Documentation
- Easy-to-use APIs and Driver Libraries

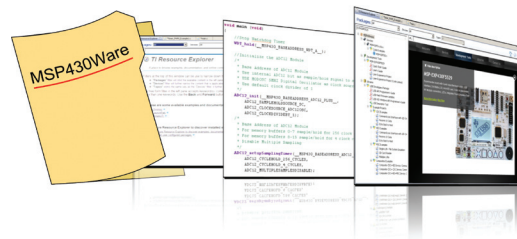

Integrated Development Environments

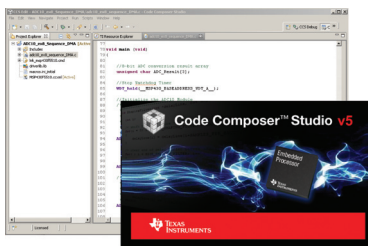

Code Composer Studio™ IDE

- Eclipse-based IDE (Compiler, debugger, link, etc) for all TI embedded processors
- Version 5.1 now available. Faster, more efficient and simple user interface
- Unrestricted version available for \$495
- Free versions are available as well
 - Free 16kB code-limited version available
 - Free, full-featured, 120-day trial version also available

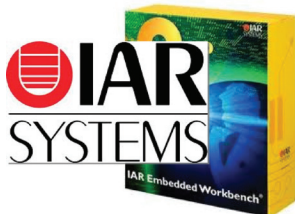

IAR Embedded Workbench

- Third-party IDE offering project management tools and code editor
- Includes up-to-date configuration files for all MSP430 devices
- Free versions are available as well
 - Free 4/8/16kB code-limited Kickstart version available
 - Free, full-featured 30-day trial version available

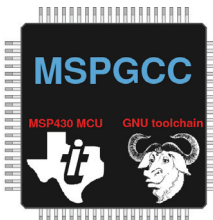
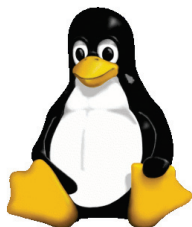

Open Source MSPGCC and MSPDEBUG

- Free, open source toolchain for MSP430 devices
- Includes the GNU C compiler (GCC), the assembler and linker and the debugger (GDB)
- Tools can be used on Windows, Linux, BSD and most other versions of Unix
- Learn more at mspgcc.sourceforge.net

MSP430™ MCU Software Tools

The Brand New MSP430 Driver Library

Makes it easy for developers to program MSP430F5xx and 6xx devices using easy-to-use and well-documented function calls; all with minimal footprint. Tap into MSP430 hardware fast and efficiently.

Key features:

- Easy-to-use function calls for enabling, configuring and using peripherals including ADCs, DACs, timers, serial communication modules and more
- Supports MSP430F5xx and F6xx devices today
- Fully documented within a comprehensive API Guide
- Driver Library and documentation delivered within MSP430Ware
- Royalty-free and open source

Driver Library

```
GPIO_setAsPeripheralModuleFunctionOutputPin (PARAMETERS);
Timer_generatePWM(PARAMETERS)
```

Traditional Code

```
P2DIR 1 = 0x04;
TA1CCTL1 = OUTMOD_7;
P2SEL 1 = 0x04;
TA1CCR1 = 38R;
TA1CCRO = 511;
TA1CTL = TASSEL_1 = MC_1 = TACLR;
```

Low level Programming

```
00101010
10010010
01010100
10010010
11001010
```



Grace™ Software GUI-based I/O and peripheral configuration tool for MSP430F2xx/G2xx devices

Get started quickly with Grace code generation

Grace enables developers to generate easy-to-read, fully commented C code that enables and configures peripherals quickly, so developers can spend more time differentiating within the application layer.

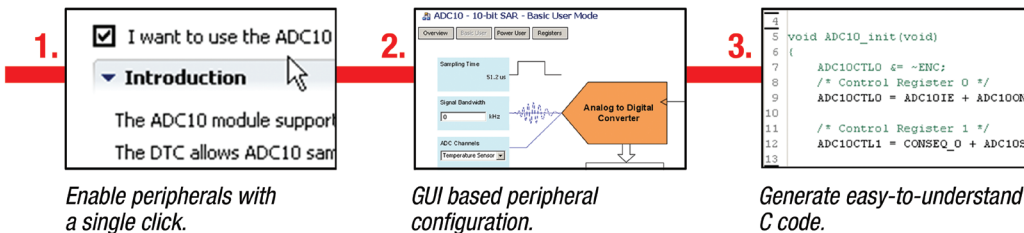
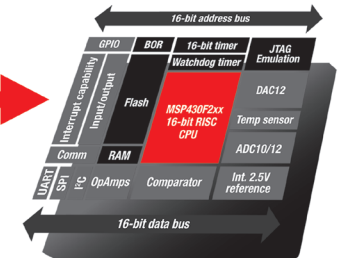

Other MSP430 Software Resources Tools Get up and running with MSP430 Software Ecosystem



MSP430 USB Developers Package (MSC, HID, CDC)



MSP430 RF Software tools and wireless stacks

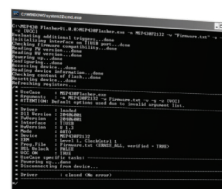

Command line programmers



Capacitive Touch Software Libraries

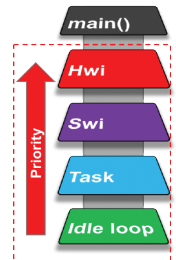

Real-Time Operating Systems

MSP430 Software Ecosystem

MSP430 offers software solutions and documentation that enable multiple applications such as metering, medical, wireless, energy harvesting, capacitive touch and other applications. See the MSP430 Software Ecosystem in its entirety at www.ti.com/msp430software

MSP430™ MCU Hardware Tools

MSP430 is supported by a broad collection of hardware development tools, ranging from low-cost development kits like the \$4.30 LaunchPad (MSP-EXP430G2) to highly-integrated, application-specific platforms. MSP430 development kits are carefully put together to ensure a simple “out-of-box” experience to get users beyond “Hello World” within minutes. In addition to a large selection of TI-generated development kits, a growing and active third party network is also available. Happy Coding!

LaunchPad and the BoosterPack Ecosystem

Complete Development kit for \$4.30!

The MSP-EXP430G2 LaunchPad development kit provides all of the hardware and software needed to start MSP430 development. LaunchPad supports all MSP430G2xx Value Line MCUs. www.ti.com/launchpad

LaunchPad Features

- On-board emulation
- 20-pin DIP Socket
- 2 on-board LEDs and 2 on-board switches
- Kit includes USB cable, Quick Start Guide, 2x 10-pin male and female headers
- Includes 2 MSP430 Value Line MCUs

- **MSP430G2553:** 16kB Flash, 512B RAM, 8ch 10-bit ADC, Comparator, Capacitive Touch I/Os, Universal Serial Communication Module (I²C, UART, SPI)
- **MSP430G2452:** 8kB Flash, 256B RAM, 8ch 10-bit ADC, Comparator, Capacitive Touch I/Os, Universal Serial Interface (I²C/SPI)

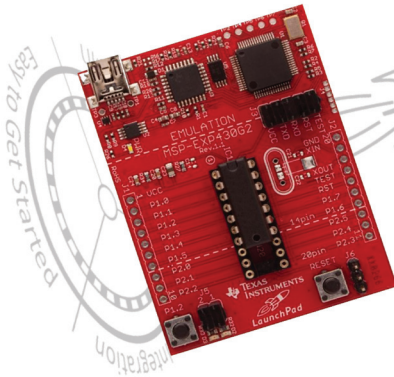

Growing Ecosystem of BoosterPacks!

BoosterPacks are plug-in modules for the LaunchPad development kit, which enable additional functionality including wireless, capacitive touch, LED lighting and others. Each BoosterPack includes hardware, documentation and a pre-programmed MSP430 Value Line device which includes a demo application. See the complete list of BoosterPacks at www.ti.com/boosterpack

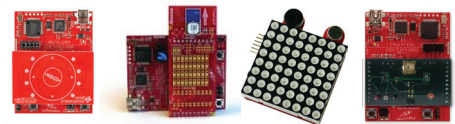

eZ430 Starter Kits

eZ430 kits feature embedded emulation and unique form factors.

The eZ430 family of tools feature embedded emulation, allowing the kit to be the same size as a USB memory stick and communicate with the target MCU using only 2 pins!

Featuring the eZ430-Chronos™ development tool

- The world's first wireless development kit in a sports watch
- Integrated with the CC430F6137, an MCU + RF system-on-chip
- Available in three RF frequencies: 433, 868 & 915MHz
- Highly-integrated development platform featuring 3-axis accelerometer, pressure sensor, temp sensor and 96-segment LCD
- Learn more at www.ti.com/chronoswiki





Part Number	Description	Picture	Price
eZ430-Chronos	CC430-based RF wireless development kit in a sports watch (433, 868 & 915MHz)		\$49
eZ430-F2013	Development kit in USB thumb drive form-factor. Based on MSP430F2013		\$20
eZ430-T2012	3x MSP430F2012 target boards that support the eZ430-F2013 emulator		\$10
eZ430-RF2500	2.4GHz RF development kit based on MSP430F2274. Ideal for those new to wireless		\$49
eZ430-F2500T	Standalone 2.4GHz target board that is also included in the eZ430-RF2500 kit		\$20
eZ430-RF2500-SEH	Solar Energy Harvesting kit featuring 2.4GHz RF and Cymbet's rechargeable EnerChips		\$149
eZ430-RF256x	Bluetooth kit based on MSP430BT5190 (pre-eZ430-RF256x loaded with Bluetooth stack) and CC2560A		\$99
eZ430-TMS37157	RFID/Passive Low Frequency kit includes base station, target board and USB emulator		\$199

MSP430™ MCU Hardware Tools

MSP430 Experimenter's Boards

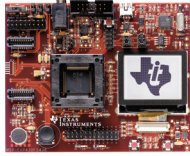
Highly integrated development platforms for evaluating MSP430 devices.

Experimenter's Boards feature selected MSP430 devices and additional hardware components for easy system evaluation and prototyping. They are the ideal platform for learning a new architecture and testing the capabilities of a device family.

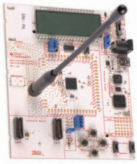
				
<p>MSP-EXP430F5438 Featuring MSP430F5438 on-board dot matrix display, joystick, ZIF socket, RF headers, microphone, accelerometer, JTAG Price: \$149</p>	<p>MSP-EXP430FG4618 Featuring MSP430FG4618 and MSP430F2013 on-board segmented display, buzzer, RS-232, capacitive touch, microphone, RF headers, JTAG Price: \$149</p>	<p>MSP-EXP430F5529 Featuring MSP430F5529 complete USB development platform, on-board dot matrix display, JTAG, RF headers, on-board emulation, accelerometer, microSD, capacitive touch Price: \$149</p>	<p>MSP-EXP430FR5739 Featuring MSP430FR5739 on-board emulation, RF headers, accelerometer, temperature sensor, first catalog MCU with embedded FRAM Price: \$29</p>	<p>MSP-EXP430F6137RFx Featuring CC430F6137 and CC430F5137 on-board emulation, segmented LCD, light sensor, includes F6137-based motherboard and F5137-based satellite board Price: \$149</p>

Preview products are listed in blue.

Target Boards and Flash Emulation Tools

One tool to rule them all.

The MSP430 Flash Emulation Tool (MSP-FET430UIF) supports all MSP430 devices when paired with the appropriate target board.

Target Boards are available for all MSP430 devices and are fitted with ZIF target sockets for interfacing with various package types and pinouts. The boards provide direct access to all port pins and include an on-board JTAG connector.

A Flash Emulation Tool is required to interface each target board with a PC. The target boards (~\$75) and Flash Emulation Tool (~\$99) can be purchased separately, or as a bundle (~\$149).

Debugging and Programming Tools			
Part Number	PC Port	Price	
MSP-FET430UIF (recommended)	USB	\$99	
MSP-FET430PIF	Parallel	\$20	
Production Programmer			
Part Number	PC Port	Provider	Price
MSP-GANG (recommended)	Serial/USB	TI	\$249
MSP-GANG430	Serial	TI	\$199
GangPro430	USB	Elprotronic	\$339

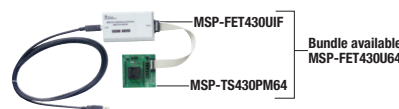

Socket Pin Count	Package Supported	FET + TS Bundle	Target Board Only	Supported Devices														
8	D (SOIC)	MSP-FET430U8	MSP-TS430D8	G2xx0														
14	PW (TSSOP)	MSP-FET430U14	MSP-TS430PW14	F20xx	G2xx1													
	PW (TSSOP)	MSP-FET430U092	MSP-TS430L092	L092														
24	PW (TSSOP)	MSP-FET430U24	MSP-TS430PW24	AFE2xx														
	DW (TSSOP)	--	MSP-TS430DW28	F12x	F12x2													
28	PW (TSSOP)	MSP-FET430U28	MSP-TS430PW28	F11x1	F11x2	F12x	F12x2	F21xx										
	PW (TSSOP)	MSP-FET430U28A	MSP-TS430PW28A	F20xx	G2xx1	G2xx2	G2xx3											
38	DA (TSSOP)	MSP-FET430U38	MSP-TS430DA38	F22x2	F22x4													
	RHA (QFN)	MSP-FET430U40A	MSP-TS430RHA40A	FR572x	FR573x													
40	RHA (QFN)	MSP-FET430U23x0	MSP-TS430QFN23x0	F23x0														
	RSB (QFN)	MSP-FET430U40	MSP-TS430RSB40	F51x1	F51x2													
48	DL (SSOP)	MSP-FET430U48	MSP-TS430DL48	F42x0	FG42x0													
	RGZ (QFN)	MSP-FET430U48B	MSP-TS430RGZ48B	F534x														
64	PM (QFP)	MSP-FET430U64	MSP-TS430PM64	F13x	F13x1	F14x	F14x1	F15x	F16x	F23x	F24x	F2410						
	PM (QFP)	MSP-FET430U64A	MSP-TS430PM64A	F24x1	F241x	F261x	F41x	F42x	FE42x	FE42x2	FW42x							
	RGC (QFN)	MSP-FET430U64B	MSP-TS430PM64B	F41x2														
	RGC (QFN)	MSP-FET430U64C	MSP-TS430PM64C	F530x	F5310													
	RGC (QFN)	FET430F6137RF900	EM430F6137RF900	F522x	CC430F6137													
	RGC (QFN)	MSP-FET430U64USB	MSP-TS430RGC64USB	F552x	F551x	F55x0												
	PN (QFP)	MSP-FET430U80	MSP-TS430PN80	F241x	F261x	F43x	F43x1	FG43x	F47x	FG47x								
80	PN (LQFP)	MSP-FET430U80A	MSP-TS430PN80A	F532x														
	PN (LQFP)	MSP-FET430U80USB	MSP-TS430PN80USB	F552X	F551x													
100	PZ (QFP)	MSP-FET430U100	MSP-TS430PZ100	F43x	F43x1	F44x	FG461x	F47xx	F461x									
	PZ (QFP)	MSP-FET430U100A	MSP-TS430PZ100A	F471xx														
	PZ (QFP)	MSP-FET430U100B	MSP-TS430PZ100B	F673x	F672x													
	PZ (QFP)	MSP-FET430U100C	MSP-TS430PZ100C	F643x	F533x													
	PZ (QFP)	MSP-FET430U5x100	MSP-TS430PZ5x100	F54xx														
	PZ (QFP)	MSP-FET430U100USB	MSP-TS430PZ100USB	F56xx	F663x													

Join our online community at www.ti.com/e2e-mcu

Application-Specific MSP430 Devices

Application	Part Number	Flash (KB)	SRAM (KB)	16-Bit Timers			ADC	Additional Features	Related Devices	Package(s)	1 ku Price ¹
				Total	A*	B*					
Low Voltage (0.9V)	MSP430I092	—	2	2	2	—	ADC8	DAC8, COMP, SVS, Temp sensor, 11 I/Os, ROM-version available	—	14PW	\$1.00
Bluetooth	MSP430BT5190	256	16	3	5, 3	7	16ch ADC12_A	MindTree's Ethermind Bluetooth stack and Serial Port Profile available for download. Not preloaded by default.	CC2560	100PZ, 113ZQW	\$4.95
Contactless Power	MSP430BQ1010	—	—	—	—	—	—	Fixed-Function, Qi-certified software for contactless power applications (Receiver). Compliant with the Wireless Power Consortium. Comes pre-loaded by default.	BQ25046, BQ500110	—	\$1.80

¹Prices are quoted in U.S. dollars and represent year 2012 suggested resale price. *Represents number of capture/compare registers per timer.

MSP430F1xx Series – Up to 8 MHz

Series	Part Number	Flash (KB)	SRAM (B)	I/O (max)	Timers			Watchdog	BOR	SVS	USART (UART/SPI)	DMA	MPY	Comp. A+	Temp Sensor	ADC Ch/Res	Additional Features	Package(s)	1 ku Price ¹
					Total	A*	B*												
F1x1	MSP430F1101A	1	128	14	1	3	—	●	—	—	—	—	—	—	—	Slope	—	20DGV, DW, PW; 24RGE	\$1.06
	MSP430F1111A	2	128	14	1	3	—	●	—	—	—	—	—	—	—	Slope	—	20DGV, DW, PW; 24RGE	\$1.22
	MSP430F1121A	4	256	14	1	3	—	●	—	—	—	—	—	—	—	Slope	—	20DGV, DW, PW; 24RGE	\$1.56
F1x2	MSP430F1122	4	256	14	1	3	—	●	●	—	—	—	—	—	●	5ch/ADC10	—	20DW, PW; 32RHB	\$1.67
	MSP430F1132	8	256	14	1	3	—	●	●	—	—	—	—	—	●	5ch/ADC10	—	20DW, PW; 32RHB	\$1.78
F2x	MSP430F122	4	256	22	1	3	—	●	—	—	1	—	—	—	—	Slope	—	28DW, PW; 32RHB	\$1.67
	MSP430F123	8	256	22	1	3	—	●	—	—	1	—	—	—	—	Slope	—	28DW, PW; 32RHB	\$1.72
F2x2	MSP430F1222	4	256	22	1	3	—	●	●	—	1	—	—	—	●	8ch/ADC10	—	28DW, PW; 32RHB	\$1.72
	MSP430F1232	8	256	22	1	3	—	●	●	—	1	—	—	—	●	8ch/ADC10	—	28DW, PW; 32RHB	\$1.83
F3x	MSP430F133	8	256	48	2	3	3	●	—	—	1	—	—	—	●	8ch/ADC12	—	64PM, PAG, RTD	\$2.94
	MSP430F135	16	512	48	2	3	3	●	—	—	1	—	—	—	●	8ch/ADC12	—	64PM, PAG, RTD	\$3.28
F3x1	MSP430F1331	8	256	48	2	3	3	●	—	—	1	—	—	—	—	Slope	—	64PM, R TD	\$2.00
	MSP430F1351	16	512	48	2	3	3	●	—	—	1	—	—	—	—	Slope	—	64PM, RTD	\$2.30
F4x	MSP430F147	32	1024	48	2	3	7	●	—	—	2	—	16x16	—	●	8ch/ADC12	—	64PM, PAG, RTD	\$4.00
	MSP430F148	48	2048	48	2	3	7	●	—	—	2	—	16x16	—	●	8ch/ADC12	—	64PM, PAG, RTD	\$4.33
	MSP430F149	60	2048	48	2	3	7	●	—	—	2	—	16x16	—	●	8ch/ADC12	—	64PM, PAG, RTD	\$4.66
	MSP430F1471	32	1024	48	2	3	7	●	—	—	2	—	16x16	—	—	Slope	—	64PM, RTD	\$4.55
	MSP430F1481	48	2048	48	2	3	7	●	—	—	2	—	16x16	—	—	Slope	—	64PM, RTD	\$5.11
F5x	MSP430F1491	60	2048	48	2	3	7	●	—	—	2	—	16x16	—	—	Slope	—	64PM, RTD	\$5.11
	MSP430F155	16	512	48	2	3	3	●	●	●	1 with I ² C	●	—	—	●	8ch/ADC12	(2) DAC12	64PM, RTD	\$5.38
	MSP430F156	24	1024	48	2	3	3	●	●	●	1 with I ² C	●	—	—	●	8ch/ADC12	(2) DAC12	64PM, RTD	\$5.61
F6x	MSP430F157	32	1024	48	2	3	3	●	●	●	1 with I ² C	●	—	—	●	8ch/ADC12	(2) DAC12	64PM, RTD	\$5.95
	MSP430F167	32	1024	48	2	3	7	●	●	●	2 with I ² C	●	16x16	—	●	8ch/ADC12	(2) DAC12	64PM, RTD	\$6.88
	MSP430F168	48	2048	48	2	3	7	●	●	●	2 with I ² C	●	16x16	—	●	8ch/ADC12	(2) DAC12	64PM, RTD	\$7.61
	MSP430F169	60	2048	48	2	3	7	●	●	●	2 with I ² C	●	16x16	—	●	8ch/ADC12	(2) DAC12	64PM, RTD	\$8.16
	MSP430F1610	32	5120	48	2	3	7	●	●	●	2 with I ² C	●	16x16	—	●	8ch/ADC12	(2) DAC12	64PM, RTD	\$8.72
	MSP430F1611	48	10240	48	2	3	7	●	●	●	2 with I ² C	●	16x16	—	●	8ch/ADC12	(2) DAC12	64PM, RTD	\$9.16
MSP430F1612	55	5120	48	2	3	7	●	●	●	2 with I ² C	●	16x16	—	●	8ch/ADC12	(2) DAC12	64PM, RTD	\$9.50	

¹Prices are quoted in U.S. dollars and represent year 2012 suggested resale price. *Represents number of capture/compare registers per timer.

MSP430G2xx Series – Up to 16 MHz

Series	Part Number	Flash (KB)	SRAM (B)	I/O (max)	Timers			Watchdog	BOR	USI: I ² C/SPI	USCI: I ² C/SPI/UART	Comp. A+	Temp Sensor	ADC Ch/Res	Additional Features	Packages	1ku Price ¹
					Total	A*	B*										
G2xx1	MSP430G2001	0.5	128	10	1	2	—	●	●	—	—	—	—	—	—	14PW, N; 16RSA	\$0.34
	MSP430G2101	1	128	10	1	2	—	●	●	—	—	—	—	—	—	14PW, N; 16RSA	\$0.44
	MSP430G2121	1	128	10	1	2	—	●	●	●	—	—	—	—	—	14PW, N; 16RSA	\$0.46
	MSP430G2201	2	128	10	1	2	—	●	●	—	—	—	—	—	—	14PW, N; 16RSA	\$0.47
	MSP430G2221	2	128	10	1	2	—	●	●	●	—	—	—	—	—	14PW, N; 16RSA	\$0.49
	MSP430G2111	1	128	10	1	2	—	●	●	—	—	—	—	Slope	—	14PW, N; 16RSA	\$0.46
	MSP430G2211	2	128	10	1	2	—	●	●	—	—	—	—	Slope	—	14PW, N; 16RSA	\$0.49
	MSP430G2131	1	128	10	1	2	—	●	●	●	—	—	—	8ch/ADC10	—	14PW, N; 16RSA	\$0.49
	MSP430G2231	2	128	10	1	2	—	●	●	●	—	—	—	8ch/ADC10	—	14PW, N; 16RSA	\$0.55

¹Prices are quoted in U.S. dollars and represent year 2012 suggested resale price for TSSOP package. *Represents number of capture/compare registers per timer.

MSP430G2xx Series – Up to 16 MHz (continued)

Series	Part Number	Flash (KB)	SRAM (B)	I/O (max)	Timers		Watchdog	BOR	USI: I ² C/SPI	USCI: I ² C/SPI/UART	Comp_A+	Temp Sensor	ADC Ch/Res	Additional Features	Packages	1ku Price ¹
					Total	A*										
G2xx2	MSP430G2102	1	256	16	1	3	●	●	●	—	—	—	—	Cap touch I/O	14PW; 20PW, N; 16RSA	\$0.48
	MSP430G2202	2	256	16	1	3	●	●	●	—	—	—	—	Cap touch I/O	14PW; 20PW, N; 16RSA	\$0.50
	MSP430G2302	4	256	16	1	3	●	●	●	—	—	—	—	Cap touch I/O	14PW; 20PW, N; 16RSA	\$0.55
	MSP430G2402	8	256	16	1	3	●	●	●	—	—	—	—	Cap touch I/O	14PW; 20PW, N; 16RSA	\$0.65
	MSP430G2112	1	256	16	1	3	●	●	●	—	●	—	Slope	Cap touch I/O	14PW; 20PW, N; 16RSA	\$0.49
	MSP430G2212	2	256	16	1	3	●	●	●	—	●	—	Slope	Cap touch I/O	14PW; 20PW, N; 16RSA	\$0.55
	MSP430G2312	4	256	16	1	3	●	●	●	—	●	—	Slope	Cap touch I/O	14PW; 20PW, N; 16RSA	\$0.60
	MSP430G2412	8	256	16	1	3	●	●	●	—	●	—	Slope	Cap touch I/O	14PW; 20PW, N; 16RSA	\$0.65
	MSP430G2132	1	256	16	1	3	●	●	●	—	●	●	8ch/ADC10	Cap touch I/O	14PW; 20PW, N; 16RSA	\$0.55
	MSP430G2232	2	256	16	1	3	●	●	●	—	●	●	8ch/ADC10	Cap touch I/O	14PW; 20PW, N; 16RSA	\$0.55
	MSP430G2332	4	256	16	1	3	●	●	●	—	●	●	8ch/ADC10	Cap touch I/O	14PW; 20PW, N; 16RSA	\$0.60
	MSP430G2432	8	256	16	1	3	●	●	●	—	●	●	8ch/ADC10	Cap touch I/O	14PW; 20PW, N; 16RSA	\$0.70
	MSP430G2152	1	256	16	1	3	●	●	●	—	●	●	8ch/ADC10	Cap touch I/O	14PW; 20PW, N; 16RSA	\$0.55
	MSP430G2252	2	256	16	1	3	●	●	●	—	●	●	8ch/ADC10	Cap touch I/O	14PW; 20PW, N; 16RSA	\$0.60
MSP430G2352	4	256	16	1	3	●	●	●	—	●	●	8ch/ADC10	Cap touch I/O	14PW; 20PW, N; 16RSA	\$0.65	
MSP430G2452	8	256	16	1	3	●	●	●	—	●	●	8ch/ADC10	Cap touch I/O	14PW; 20PW, N; 16RSA	\$0.70	
G2xx3	MSP430G2203	2	256	24	2	3,3	●	●	—	●	—	—	—	Cap touch I/O	20PW, N; 28PW; 32RHB	\$0.60
	MSP430G2303	4	256	24	2	3,3	●	●	—	●	—	—	—	Cap touch I/O	20PW, N; 28PW; 32RHB	\$0.65
	MSP430G2403	8	512	24	2	3,3	●	●	—	●	—	—	—	Cap touch I/O	20PW, N; 28PW; 32RHB	\$0.75
	MSP430G2213	2	256	24	2	3,3	●	●	—	●	●	—	Slope	Cap touch I/O	20PW, N; 28PW; 32RHB	\$0.65
	MSP430G2313	4	256	24	2	3,3	●	●	—	●	●	—	Slope	Cap touch I/O	20PW, N; 28PW; 32RHB	\$0.70
	MSP430G2413	8	512	24	2	3,3	●	●	—	●	●	—	Slope	Cap touch I/O	20PW, N; 28PW; 32RHB	\$0.75
	MSP430G2513	16	512	24	2	3,3	●	●	—	●	●	—	Slope	Cap touch I/O	20PW, N; 28PW; 32RHB	\$0.90
	MSP430G2233	2	256	24	2	3,3	●	●	—	●	●	—	8ch/ADC10	Cap touch I/O	20PW, N; 28PW; 32RHB	\$0.65
	MSP430G2333	4	256	24	2	3,3	●	●	—	●	●	—	8ch/ADC10	Cap touch I/O	20PW, N; 28PW; 32RHB	\$0.70
	MSP430G2433	8	512	24	2	3,3	●	●	—	●	●	—	8ch/ADC10	Cap touch I/O	20PW, N; 28PW; 32RHB	\$0.75
	MSP430G2533	16	512	24	2	3,3	●	●	—	●	●	—	8ch/ADC10	Cap touch I/O	20PW, N; 28PW; 32RHB	\$0.90
	MSP430G2153	1	256	24	2	3,3	●	●	—	●	●	●	8ch/ADC10	Cap touch I/O	20PW, N; 28PW; 32RHB	\$0.60
	MSP430G2253	2	256	24	2	3,3	●	●	—	●	●	●	8ch/ADC10	Cap touch I/O	20PW, N; 28PW; 32RHB	\$0.65
	MSP430G2353	4	256	24	2	3,3	●	●	—	●	●	●	8ch/ADC10	Cap touch I/O	20PW, N; 28PW; 32RHB	\$0.70
MSP430G2453	8	512	24	2	3,3	●	●	—	●	●	●	8ch/ADC10	Cap touch I/O	20PW, N; 28PW; 32RHB	\$0.80	
MSP430G2553	16	512	24	2	3,3	●	●	—	●	●	●	8ch/ADC10	Cap touch I/O	20PW, N; 28PW; 32RHB	\$0.90	

¹Prices are quoted in U.S. dollars and represent year 2012 suggested resale price. *Represents number of capture/compare registers per timer.

MSP430F2xx Series – Up to 16 MHz

Series	Part Number	Flash (KB)	SRAM (B)	I/O (max)	Timers			Watchdog	BOR	SVS	USI: I ² C/SPI	USCI		DMA	MPY	Comp_A+	Temp Sensor	ADC Ch/Res	Additional Features	Package(s)	1ku Price ¹
					Total	A*	B*					Ch A: UART/LIN/IrDA/SPI	Ch B: I ² C/SPI								
F20xx	MSP430F2001	1	128	10	1	2	—	●	●	—	—	—	—	—	—	●	—	Slope	—	14PW, N; 16RSA	\$0.55
	MSP430F2011	2	128	10	1	2	—	●	●	—	—	—	—	—	—	●	—	Slope	—	14PW, N; 16RSA	\$0.65
	MSP430F2002	1	128	10	1	2	—	●	●	—	●	—	—	—	—	—	●	8ch/ADC10	—	14PW, N; 16RSA	\$0.80
	MSP430F2012	2	128	10	1	2	—	●	●	—	●	—	—	—	—	—	●	8ch/ADC10	—	14PW, N; 16RSA	\$0.95
	MSP430F2003	1	128	10	1	2	—	●	●	—	●	—	—	—	—	—	●	4ch/SD16_A	—	14PW, N; 16RSA	\$1.20
	MSP430F2013	2	128	10	1	2	—	●	●	—	●	—	—	—	—	—	●	4ch/SD16_A	—	14PW, N; 16RSA	\$1.35
F21xx	MSP430F2101	1	128	16	1	3	—	●	●	—	—	—	—	—	—	●	—	Slope	—	20DGV, DW, PW; 24RGE	\$0.75
	MSP430F2111	2	128	16	1	3	—	●	●	—	—	—	—	—	—	●	—	Slope	—	20DGV, DW, PW; 24RGE	\$0.80
	MSP430F2121	4	256	16	1	3	—	●	●	—	—	—	—	—	—	●	—	Slope	—	20DGV, DW, PW; 24RGE	\$1.10
	MSP430F2131	8	256	16	1	3	—	●	●	—	—	—	—	—	—	●	—	Slope	—	20DGV, DW, PW; 24RGE	\$1.40
	MSP430F2112	2	256	22	2	3,2	—	●	●	—	—	1	1	—	—	●	●	8ch/ADC10	—	28PW; 32RHB, RTV	\$1.55
	MSP430F2122	4	512	22	2	3,2	—	●	●	—	—	1	1	—	—	●	●	8ch/ADC10	—	28PW; 32RHB, RTV	\$1.65
F22xx	MSP430F2132	8	512	22	2	3,2	—	●	●	—	—	1	1	—	—	●	●	8ch/ADC10	—	28PW; 32RHB, RTV	\$1.75
	MSP430F2232	8	512	32	2	3	3	●	●	—	—	1	1	—	—	●	●	12ch/ADC10	—	38DA; 40RHA, 49YFF	\$1.95
	MSP430F2252	16	512	32	2	3	3	●	●	—	—	1	1	—	—	●	●	12ch/ADC10	—	38DA; 40RHA, 49YFF	\$2.20
	MSP430F2272	32	1024	32	2	3	3	●	●	—	—	1	1	—	—	●	●	12ch/ADC10	—	38DA; 40RHA, 49YFF	\$2.50
F22x4	MSP430F2234	8	512	32	2	3	3	●	●	—	—	1	1	—	—	●	●	12ch/ADC10	(2) OPAMP	38DA; 40RHA, 49YFF	\$2.15
	MSP430F2254	16	512	32	2	3	3	●	●	—	—	1	1	—	—	●	●	12ch/ADC10	(2) OPAMP	38DA; 40RHA, 49YFF	\$2.40
	MSP430F2274	32	1024	32	2	3	3	●	●	—	—	1	1	—	—	●	●	12ch/ADC10	(2) OPAMP	38DA; 40RHA, 49YFF	\$2.70
F23x0	MSP430F2330	8	1024	32	2	3	3	●	●	—	—	1	1	—	16x16	●	—	Slope	—	40RHA; 49YFF	\$1.85
	MSP430F2350	16	2048	32	2	3	3	●	●	—	—	1	1	—	16x16	●	—	Slope	—	40RHA; 49YFF	\$2.15
	MSP430F2370	32	2048	32	2	3	3	●	●	—	—	1	1	—	16x16	●	—	Slope	—	40RHA; 49YFF	\$2.55

¹Prices are quoted in U.S. dollars and represent year 2012 suggested resale price. *Represents number of capture/compare registers per timer.

MSP430F2xx Series – Up to 16 MHz (continued)

Series	Part Number	Flash (KB)	SRAM (B)	I/O (max)	Timers			Watchdog	BOR	SVS	USI: (I ² C/SPI)	USCI		DMA	MPY	Comp_A+	Temp Sensor	ADC Ch/Res	Additional Features	Package(s)	1 ku Price ¹
					Ch A: UART/LIN/IrDA/SPI	Ch B: I ² C/SPI															
F23x	MSP430F233	8	1024	48	2	3	3	●	●	●	—	1	1	—	16x16	●	●	8ch/ADC12	—	64PM, RGC	\$2.40
	MSP430F235	16	2048	48	2	3	3	●	●	●	—	1	1	—	16x16	●	●	8ch/ADC12	—	64PM, RGC	\$2.90
F24x/10	MSP430F247	32	4096	48	2	3	7	●	●	●	—	2	2	—	16x16	●	●	8ch/ADC12	—	64PM, RGC	\$4.05
	MSP430F248	48	4096	48	2	3	7	●	●	●	—	2	2	—	16x16	●	●	8ch/ADC12	—	64PM, RGC	\$4.60
	MSP430F249	60	2048	48	2	3	7	●	●	●	—	2	2	—	16x16	●	●	8ch/ADC12	—	64PM, RGC	\$4.75
	MSP430F2410	56	4096	48	2	3	7	●	●	●	—	2	2	—	16x16	●	●	8ch/ADC12	—	64PM, RGC	\$4.85
F24x1	MSP430F2471	32	4096	48	2	3	7	●	●	●	—	2	2	—	16x16	●	—	Slope	—	64PM, RGC	\$3.70
	MSP430F2481	48	4096	48	2	3	7	●	●	●	—	2	2	—	16x16	●	—	Slope	—	64PM, RGC	\$4.25
	MSP430F2491	60	2048	48	2	3	7	●	●	●	—	2	2	—	16x16	●	—	Slope	—	64PM, RGC	\$4.40
F241x	MSP430F2416	92	4096	48/64	2	3	7	●	●	●	—	2	2	—	16x16	●	●	8ch/ADC12	—	64PM; 80PN; 113ZQW	\$5.60
	MSP430F2417	92	8192	48/64	2	3	7	●	●	●	—	2	2	—	16x16	●	●	8ch/ADC12	—	64PM; 80PN; 113ZQW	\$6.10
	MSP430F2418	116	8192	48/64	2	3	7	●	●	●	—	2	2	—	16x16	●	●	8ch/ADC12	—	64PM; 80PN; 113ZQW	\$6.40
	MSP430F2419	120	4096	48/64	2	3	7	●	●	●	—	2	2	—	16x16	●	●	8ch/ADC12	—	64PM; 80PN; 113ZQW	\$6.10
F261x	MSP430F2616	92	4096	48/64	2	3	7	●	●	●	—	2	2	●	16x16	●	●	8ch/ADC12	(2) DAC12	64PM; 80PN; 113ZQW	\$7.10
	MSP430F2617	92	8192	48/64	2	3	7	●	●	●	—	2	2	●	16x16	●	●	8ch/ADC12	(2) DAC12	64PM; 80PN; 113ZQW	\$7.60
	MSP430F2618	116	8192	48/64	2	3	7	●	●	●	—	2	2	●	16x16	●	●	8ch/ADC12	(2) DAC12	64PM; 80PN; 113ZQW	\$7.90
	MSP430F2619	120	4096	48/64	2	3	7	●	●	●	—	2	2	●	16x16	●	●	8ch/ADC12	(2) DAC12	64PM; 80PN; 113ZQW	\$7.60

¹Prices are quoted in U.S. dollars and represent year 2012 suggested resale price. *Represents number of capture/compare registers per timer.

MSP430AFE2xx Series – Up to 12 MHz

Series	Part Number	Flash (KB)	SRAM (B)	I/O (max)	Timers			Watchdog	BOR	SVS	USART (UART/SPI)	MPY	Comparator	Temp Sensor	ADC Ch/Res	Additional Features	Package(s)	1 ku Price ¹
					Total	A*	B*											
AFE2xx	MSP430AFE221	4	256	11	1	3	—	●	●	●	●	●	●	●	(1) SD24	—	24PW	\$1.80
	MSP430AFE222	4	256	11	1	3	—	●	●	●	●	●	●	●	(2) SD24	—	24PW	\$1.95
	MSP430AFE223	4	256	11	1	3	—	●	●	●	●	●	●	●	(3) SD24	—	24PW	\$2.10
	MSP430AFE231	8	512	11	1	3	—	●	●	●	●	●	●	●	(1) SD24	—	24PW	\$1.85
	MSP430AFE232	8	512	11	1	3	—	●	●	●	●	●	●	●	(2) SD24	—	24PW	\$2.00
	MSP430AFE233	8	512	11	1	3	—	●	●	●	●	●	●	●	(3) SD24	—	24PW	\$2.10
	MSP430AFE251	16	512	11	1	3	—	●	●	●	●	●	●	●	(1) SD24	—	24PW	\$1.90
	MSP430AFE252	16	512	11	1	3	—	●	●	●	●	●	●	●	(2) SD24	—	24PW	\$2.05
	MSP430AFE253	16	512	11	1	3	—	●	●	●	●	●	●	●	(3) SD24	—	24PW	\$2.20

¹Prices are quoted in U.S. dollars and represent year 2012 suggested resale price. *Represents number of capture/compare registers per timer.

MSP430F4xx Series – Up to 16 MHz with LCD

Series	Part Number	Flash (KB)	SRAM (B)	I/O (max)	Timers			Watchdog and Basic Timer	BOR	SVS	USART (UART/SPI)	USCI		LCD Segments	DMA	MPY	Comp_A+	Temp Sensor	CPU Speed (MIPS)	ADC Ch/Res	Additional Features	Package(s)	1 ku Price ¹
					Ch A: UART/LIN/IrDA/SPI	Ch B: I ² C/SPI																	
F41x	MSP430F412	4	256	48	1	3	—	●	●	●	—	—	—	96	—	—	●	—	8	Slope	—	64PM,RTD	\$2.60
	MSP430F413	8	256	48	1	3	—	●	●	●	—	—	—	96	—	—	●	—	8	Slope	—	64PM,RTD	\$2.95
	MSP430F415	16	512	48	2	3,5	—	●	●	●	—	—	—	96	—	—	●	—	8	Slope	—	64PM,RTD	\$3.40
	MSP430F417	32	1024	48	2	3,5	—	●	●	●	—	—	—	96	—	—	●	—	8	Slope	—	64PM,RTD	\$3.90
F41x2	MSP430F4132	8	512	56	2	3,5	—	●	●	●	—	1	1	144	—	—	●	●	8	8ch/ADC10	—	48RGZ; 64PM	\$1.70
	MSP430F4152	16	512	56	2	3,5	—	●	●	●	—	1	1	144	—	—	●	●	8	8ch/ADC10	—	48RGZ; 64PM	\$1.90
F42x	MSP430F423A	8	256	14	1	3	—	●	●	●	1	—	—	128	—	16x16	—	●	8	(3) SD16	—	64PM	\$3.55
	MSP430F425A	16	512	14	1	3	—	●	●	●	1	—	—	128	—	16x16	—	●	8	(3) SD16	—	64PM	\$4.05
	MSP430F427A	32	1024	14	1	3	—	●	●	●	1	—	—	128	—	16x16	—	●	8	(3) SD16	—	64PM	\$4.45
FW42x	MSP430FW423	8	256	48	2	3,5	—	●	●	●	—	—	—	96	—	—	●	—	8	Slope	SCAN_IF	64PM	\$2.50
	MSP430FW425	16	512	48	2	3,5	—	●	●	●	—	—	—	96	—	—	●	—	8	Slope	SCAN_IF	64PM	\$2.80
	MSP430FW427	32	1024	48	2	3,5	—	●	●	●	—	—	—	96	—	—	●	—	8	Slope	SCAN_IF	64PM	\$3.10
	MSP430FW428	48	2048	48	2	3,5	—	●	●	●	—	—	—	96	—	—	●	—	8	Slope	SCAN_IF	64PM	\$3.30
	MSP430FW429	60	2048	48	2	3,5	—	●	●	●	—	—	—	96	—	—	●	—	8	Slope	SCAN_IF	64PM	\$3.55
FE42x	MSP430FE423A	8	256	14	1	3	—	●	●	●	1	—	—	128	—	16x16	—	—	8	(3) SD16	ESP430	64PM	\$3.90
	MSP430FE425A	16	512	14	1	3	—	●	●	●	1	—	—	128	—	16x16	—	—	8	(3) SD16	ESP430	64PM	\$4.40
	MSP430FE427A	32	1024	14	1	3	—	●	●	●	1	—	—	128	—	16x16	—	—	8	(3) SD16	ESP430	64PM	\$4.95
	MSP430FE4232	8	256	14	1	3	—	●	●	●	1	—	—	128	—	16x16	—	—	8	(2) SD16	ESP430	64PM	\$3.50
	MSP430FE4242	12	512	14	1	3	—	●	●	●	1	—	—	128	—	16x16	—	—	8	(2) SD16	ESP430	64PM	\$3.70
	MSP430FE4252	16	512	14	1	3	—	●	●	●	1	—	—	128	—	16x16	—	—	8	(2) SD16	ESP430	64PM	\$3.95
F42x0	MSP430F4250	16	256	32	1	3	—	●	●	—	—	—	—	56	—	—	—	—	8	5ch, SD16_A	DAC12	48DL, RGZ	\$3.10
	MSP430F4260	24	256	32	1	3	—	●	●	—	—	—	—	56	—	—	—	—	8	5ch, SD16_A	DAC12	48DL, RGZ	\$3.45
	MSP430F4270	32	256	32	1	3	—	●	●	—	—	—	—	56	—	—	—	—	8	5ch, SD16_A	DAC12	48DL, RGZ	\$3.80

¹Prices are quoted in U.S. dollars and represent year 2012 suggested resale price. *Represents number of capture/compare registers per timer.

MSP430F4xx Series – Up to 16 MHz with LCD (continued)

Series	Part Number	Flash (KB)	SRAM (B)	I/O (max)	Timers			Watchdog and Basic Timer	BOR	SVS	USART (UART/SPI)	USCI			LCD Segments	DMA	MPY	Comp A	Temp Sensor	CPU Speed (MIPS)	ADC Ch/Res	Additional Features	Package(s)	1 ku Price ¹
					Total	A*	B*					Ch A: UART/LIN/IrDA/SPI	Ch B: I ² C/SPI											
FG42x0	MSP430FG4250	16	256	32	1	3	—	●	●	—	—	—	—	56	—	—	—	●	8	5ch, SD16_A	DAC12, (2) OPAMP	48DL, RGZ	\$3.30	
	MSP430FG4260	24	256	32	1	3	—	●	●	—	—	—	—	56	—	—	—	●	8	5ch, SD16_A	DAC12, (2) OPAMP	48DL, RGZ	\$3.60	
	MSP430FG4270	32	256	32	1	3	—	●	●	—	—	—	—	56	—	—	—	●	8	5ch, SD16_A	DAC12, (2) OPAMP	48DL, RGZ	\$4.00	
F43x	MSP430F435	16	512	48	2	3	3	●	●	●	1	—	—	128/160	—	—	●	●	8	8ch/ADC12	—	80PN; 100PZ	\$3.40	
	MSP430F436	24	1024	48	2	3	3	●	●	●	1	—	—	128/160	—	—	●	●	8	8ch/ADC12	—	80PN; 100PZ	\$3.70	
	MSP430F437	32	1024	48	2	3	3	●	●	●	1	—	—	128/160	—	—	●	●	8	8ch/ADC12	—	80PN; 100PZ	\$3.90	
	MSP430F438	48	2048	48	3	3	3	—	●	●	1	—	—	128	●	—	●	●	8	12ch/ADC12	—	80LQFP	\$5.40	
	MSP430F439	60	2048	48	3	3	3	—	●	●	1	—	—	128	●	—	●	●	8	12ch/ADC12	—	80LQFP	\$5.95	
F43x1	MSP430F4351	16	512	48	2	3	3	●	●	●	1	—	—	128/160	—	—	●	—	8	Slope	—	80PN; 100PZ	\$2.65	
	MSP430F4361	24	1024	48	2	3	3	●	●	●	1	—	—	128/160	—	—	●	—	8	Slope	—	80PN; 100PZ	\$3.50	
	MSP430F4371	32	1024	48	2	3	3	●	●	●	1	—	—	128/160	—	—	●	—	8	Slope	—	80PN; 100PZ	\$3.60	
FG43x	MSP430FG437	32	1024	48	2	3	3	●	●	●	1	—	—	128	●	—	●	●	8	12ch/ADC12	(2) DAC12, (3) OPAMP	80PN	\$3.85	
	MSP430FG438	48	2048	48	2	3	3	●	●	●	1	—	—	128	●	—	●	●	8	12ch/ADC12	(2) DAC12, (3) OPAMP	80PN	\$4.50	
	MSP430FG439	60	2048	48	2	3	3	●	●	●	1	—	—	128	●	—	●	●	8	12ch/ADC12	(2) DAC12, (3) OPAMP	80PN	\$5.25	
F44x	MSP430F4481	48	2048	48	2	3	7	●	●	●	2	—	—	160	—	16x16	●	—	8	—	—	100PZ	\$4.05	
	MSP430F4491	60	2048	48	2	3	7	●	●	●	2	—	—	160	—	16x16	●	—	8	—	—	100PZ	\$4.40	
	MSP430F447	32	1024	48	2	3	7	●	●	●	2	—	—	160	—	16x16	●	●	8	8ch/ADC12	—	100PZ	\$4.05	
	MSP430F448	48	2048	48	2	3	7	●	●	●	2	—	—	160	—	16x16	●	●	8	8ch/ADC12	—	100PZ	\$4.35	
	MSP430F449	60	2048	48	2	3	7	●	●	●	2	—	—	160	—	16x16	●	●	8	8ch/ADC12	—	100PZ	\$4.65	
FG461x	MSP430FG4616	92	4096	80	2	3	7	●	●	●	1	1	1	160	●	16x16	●	●	8	12ch/ADC12	(2) DAC12, +RTC (3) OPAMP	100PZ; 113ZQW	\$7.45	
	MSP430FG4617	92	8192	80	2	3	7	●	●	●	1	1	1	160	●	16x16	●	●	8	12ch/ADC12	(2) DAC12, +RTC (3) OPAMP	100PZ; 113ZQW	\$7.95	
	MSP430FG4618	116	8192	80	2	3	7	●	●	●	1	1	1	160	●	16x16	●	●	8	12ch/ADC12	(2) DAC12, +RTC (3) OPAMP	100PZ; 113ZQW	\$8.35	
	MSP430FG4619	120	4096	80	2	3	7	●	●	●	1	1	1	160	●	16x16	●	●	8	12ch/ADC12	(2) DAC12, +RTC (3) OPAMP	100PZ; 113ZQW	\$7.95	
F461x	MSP430F46161	92	4096	80	2	3	7	●	●	●	1	1	1	160	●	16x16	●	—	8	—	—	100PZ	\$5.40	
	MSP430F46171	92	8192	80	2	3	7	●	●	●	1	1	1	160	●	16x16	●	—	8	—	—	100PZ	\$5.80	
	MSP430F46181	116	8192	80	2	3	7	●	●	●	1	1	1	160	●	16x16	●	—	8	—	—	100PZ	\$6.20	
	MSP430F46191	120	4096	80	2	3	7	●	●	●	1	1	1	160	●	16x16	●	—	8	—	—	100PZ	\$5.80	
	MSP430F4616	92	4096	80	2	3	7	●	●	●	1	1	1	160	●	16x16	●	●	8	12ch/ADC12	—	100PZ	\$6.30	
	MSP430F4617	92	8192	80	2	3	7	●	●	●	1	1	1	160	●	16x16	●	●	8	12ch/ADC12	—	100PZ	\$6.70	
	MSP430F4618	116	8192	80	2	3	7	●	●	●	1	1	1	160	●	16x16	●	●	8	12ch/ADC12	—	100PZ	\$7.10	
	MSP430F4619	120	4096	80	2	3	7	●	●	●	1	1	1	160	●	16x16	●	●	8	12ch/ADC12	—	100PZ	\$6.70	
F47xx	MSP430F4783	48	2048	72	2	3	3	●	●	●	—	2	2	160	—	32x32	●	●	16	(3) SD16_A	—	100PZ	\$4.00	
	MSP430F4793	60	2560	72	2	3	3	●	●	●	—	2	2	160	—	32x32	●	●	16	(3) SD16_A	—	100PZ	\$4.30	
	MSP430F4784	48	2048	72	2	3	3	●	●	●	—	2	2	160	—	32x32	●	●	16	(4) SD16_A	—	100PZ	\$4.00	
	MSP430F4794	60	2560	72	2	3	3	●	●	●	—	2	2	160	—	32x32	●	●	16	(4) SD16_A	—	100PZ	\$4.30	
F471xx	MSP430F47163	92	4096	68	2	3	3	●	●	●	—	2	2	160	●	32x32	●	●	16	(3) SD16_A	RTC_C	100PZ	\$5.00	
	MSP430F47173	92	8192	68	2	3	3	●	●	●	—	2	2	160	●	32x32	●	●	16	(3) SD16_A	RTC_C	100PZ	\$5.10	
	MSP430F47183	116	8192	68	2	3	3	●	●	●	—	2	2	160	●	32x32	●	●	16	(3) SD16_A	RTC_C	100PZ	\$5.30	
	MSP430F47193	120	4096	68	2	3	3	●	●	●	—	2	2	160	●	32x32	●	●	16	(3) SD16_A	RTC_C	100PZ	\$5.50	
	MSP430F47126	56	4096	68	2	3	3	●	●	●	—	2	2	160	●	32x32	●	●	16	(6) SD16_A	RTC_C	100PZ	\$5.10	
	MSP430F47166	92	4096	68	2	3	3	●	●	●	—	2	2	160	●	32x32	●	●	16	(6) SD16_A	RTC_C	100PZ	\$5.70	
	MSP430F47176	92	8192	68	2	3	3	●	●	●	—	2	2	160	●	32x32	●	●	16	(6) SD16_A	RTC_C	100PZ	\$5.90	
	MSP430F47186	116	8192	68	2	3	3	●	●	●	—	2	2	160	●	32x32	●	●	16	(6) SD16_A	RTC_C	100PZ	\$7.40	
	MSP430F47196	120	4096	68	2	3	3	●	●	●	—	2	2	160	●	32x32	●	●	16	(6) SD16_A	RTC_C	100PZ	\$7.70	
	MSP430F47127	56	4096	68	2	3	3	●	●	●	—	2	2	160	●	32x32	●	●	16	(7) SD16_A	RTC_C	100PZ	\$5.20	
	MSP430F47167	92	4096	68	2	3	3	●	●	●	—	2	2	160	●	32x32	●	●	16	(7) SD16_A	RTC_C	100PZ	\$4.75	
	MSP430F47177	92	8192	68	2	3	3	●	●	●	—	2	2	160	●	32x32	●	●	16	(7) SD16_A	RTC_C	100PZ	\$4.85	
	MSP430F47187	116	8192	68	2	3	3	●	●	●	—	2	2	160	●	32x32	●	●	16	(7) SD16_A	RTC_C	100PZ	\$6.10	
	MSP430F47197	120	4096	68	2	3	3	●	●	●	—	2	2	160	●	32x32	●	●	16	(7) SD16_A	RTC_C	100PZ	\$6.35	

¹Prices are quoted in U.S. dollars and represent year 2012 suggested resale price. *Represents number of capture/compare registers per timer.

MSP430F4xx Series – Up to 16 MHz with LCD (continued)

Series	Part Number	Flash (KB)	SRAM (B)	I/O	Timers			Watchdog and Basic Timer	BOR	SVS	USART (UART/SPI)	USCI		LCD Segments	DMA	MPY	Comp A	Temp Sensor	CPU Speed (MIPS)	ADC Ch/Res	Additional Features	Package(s)	1 ku Price ¹
					Ch A: UART/LIN/IrDA/SPI	Ch B: I ² C/SPI																	
FG47x	MSP430FG477	32	2048	48	2	3	3	●	●	●	—	1	1	128	—	—	●	●	8	(5) SD16_A	DAC12, (2) OPAMP	80PN,113ZQW	\$5.50
	MSP430FG478	48	2048	48	2	3	3	●	●	●	—	1	1	128	—	—	●	●	8	(5) SD16_A	DAC12, (2) OPAMP	80PN,113ZQW	\$5.65
	MSP430FG479	60	2048	48	2	3	3	●	●	●	—	1	1	128	—	—	●	●	8	(5) SD16_A	DAC12, (2) OPAMP	80PN,113ZQW	\$6.25
F47x	MSP430F477	32	2048	48	2	3	3	●	●	●	—	1	1	128	—	—	●	●	8	(5) SD16_A	DAC12	80PN,113ZQW	\$4.70
	MSP430F478	48	2048	48	2	3	3	●	●	●	—	1	1	128	—	—	●	●	8	(5) SD16_A	DAC12	80PN,113ZQW	\$5.20
	MSP430F479	60	2048	48	2	3	3	●	●	●	—	1	1	128	—	—	●	●	8	(5) SD16_A	DAC12	80PN,113ZQW	\$5.75

¹Prices are quoted in U.S. dollars and represent year 2012 suggested resale price. *Represents number of capture/compare registers per timer.

MSP430F5xx Series – Up to 25 MHz

Series	Part Number	Program (KB)	SRAM (KB)	I/O (max)	Timers			Watchdog Timer	PMM: BOR, SVS, SVM, LDO	USCI		DMA	MPY	Comp B	Temp Sensor	ADC Ch/Res	DAC	Additional Features	Package(s)	1 ku Price ¹
					Total	A	B			Ch A: UART/LIN/IrDA/SPI	Ch B: I ² C/SPI									
F51xx	MSP430F5131	8	1	29	3	3	—	●	●	1	1	3ch	32x32	●	—	—	HiRes PWM, 5V I/O's	38DA, 40RSB	\$1.20	
	MSP430F5151	16	2	29	3	3	—	●	●	1	1	3ch	32x32	●	—	—	HiRes PWM, 5V I/O's	38DA, 40RSB	\$1.35	
	MSP430F5171	32	2	29	3	3	—	●	●	1	1	3ch	32x32	●	—	—	HiRes PWM, 5V I/O's	38DA, 40RSB	\$1.60	
	MSP430F5132	8	1	29	3	3	—	●	●	1	1	3ch	32x32	●	●	8ch/ADC10	—	HiRes PWM, 5V I/O's	38DA, 40RSB	\$1.25
	MSP430F5152	16	2	29	3	3	—	●	●	1	1	3ch	32x32	●	●	8ch/ADC10	—	HiRes PWM, 5V I/O's	38DA, 40RSB	\$1.50
	MSP430F5172	32	2	29	3	3	—	●	●	1	1	3ch	32x32	●	●	8ch/ADC10	—	HiRes PWM, 5V I/O's	38DA, 40RSB	\$1.70
F53xx	MSP430F5304	8	6	31	4	5,3,3	7	●	●	1	1	3ch	32x32	●	●	8ch/ADC10	—	—	48RGZ, 48PT	\$1.55
	MSP430F5308	16	6	47	4	5,3,3	7	●	●	2	2	3ch	32x32	●	●	12ch/ADC10	—	—	48RGZ, 48PT, 64RGC, 80ZQE	\$1.65
	MSP430F5309	24	6	47	4	5,3,3	7	●	●	2	2	3ch	32x32	●	●	12ch/ADC10	—	—	48RGZ, 48PT, 64RGC, 80ZQE	\$1.75
	MSP430F5310	32	6	47	4	5,3,3	7	●	●	2	2	3ch	32x32	●	●	12ch/ADC10	—	—	48RGZ, 48PT, 64RGC, 80ZQE	\$1.85
F532x	MSP430F5324	64	6	48	4	5,3,3	7	●	●	2	2	3ch	32x32	●	●	16ch/ADC12A	—	—	64RGC, 80ZQE	\$2.10
	MSP430F5325	64	6	63	4	5,3,3	7	●	●	2	2	3ch	32x32	●	●	16ch/ADC12A	—	—	80PN	\$2.20
	MSP430F5326	96	8	48	4	5,3,3	7	●	●	2	2	3ch	32x32	●	●	16ch/ADC12A	—	—	64 RGC, 80ZQE	\$2.45
	MSP430F5327	96	8	63	4	5,3,3	7	●	●	2	2	3ch	32x32	●	●	16ch/ADC12A	—	—	80 PN	\$2.50
	MSP430F5328	128	10	48	4	5,3,3	7	●	●	2	2	3ch	32x32	●	●	16ch/ADC12A	—	—	64RGC, 80ZQE	\$2.55
	MSP430F5329	128	10	63	4	5,3,3	7	●	●	2	2	3ch	32x32	●	●	16ch/ADC12A	—	—	80PN	\$2.60
	MSP430F5333	128	10	74	4	5,3,3	7	●	●	2	2	6ch	32x32	●	●	16ch/ADC12A	—	—	100PZ, 113ZQW	\$4.90
	MSP430F5334	192	18	74	4	5,3,3	7	●	●	2	2	6ch	32x32	●	●	16ch/ADC12A	—	—	100PZ, 113ZQW	\$5.16
	MSP430F5335	256	18	74	4	5,3,3	7	●	●	2	2	6ch	32x32	●	●	16ch/ADC12A	—	—	100PZ, 113ZQW	\$5.43
	MSP430F5336	128	18	74	4	5,3,3	7	●	●	2	2	6ch	32x32	●	●	16ch/ADC12A	●	—	100PZ, 113ZQW	\$5.65
	MSP430F5337	192	18	74	4	5,3,3	7	●	●	2	2	6ch	32x32	●	●	16ch/ADC12A	—	—	100PZ, 113ZQW	\$5.95
	MSP430F5338	256	18	74	4	5,3,3	7	●	●	2	2	6ch	32x32	●	●	16ch/ADC12A	●	—	100PZ, 113ZQW	\$6.26
F534x	MSP430F5340	64	6	38	4	5,3,3	7	●	●	2	2	3ch	32x32	●	●	9ch/ADC12A	—	—	48RGZ	\$2.15
	MSP430F5341	96	8	38	4	5,3,3	7	●	●	2	2	3ch	32x32	●	●	9ch ADC12A	—	—	48RGZ	\$2.45
	MSP430F5342	128	10	38	4	5,3,3	7	●	●	2	2	3ch	32x32	●	●	9ch/ADC12A	—	—	48RGZ	\$2.60
F54xx	MSP430F5418A	128	16	67	3	5,3	7	●	●	2	2	3ch	32x32	●	●	16ch/ADC12A	—	—	80PN	\$3.30
	MSP430F5419A	128	16	87	3	5,3	7	●	●	4	4	3ch	32x32	●	●	16ch/ADC12A	—	—	100PZ, 113ZQW	\$3.65
	MSP430F5435A	192	16	67	3	5,3	7	●	●	2	2	3ch	32x32	●	●	16ch/ADC12A	—	—	80PN	\$3.90
	MSP430F5436A	192	16	87	3	5,3	7	●	●	4	4	3ch	32x32	●	●	16ch/ADC12A	—	—	100PZ, 113ZQW	\$4.30
	MSP430F5437A	256	16	67	3	5,3	7	●	●	2	2	3ch	32x32	●	●	16ch/ADC12A	—	—	80PN	\$4.40
	MSP430F5438A	256	16	87	3	5,3	7	●	●	4	4	3ch	32x32	●	●	16ch/ADC12A	—	—	100PZ, 113ZQW	\$4.85
F55xx	MSP430F5500	8	4 + 2 ¹	31	4	5,3,3	7	●	●	1	1	3ch	32x32	●	—	—	USB	48RGZ	\$1.45	
	MSP430F5501	16	4 + 2 ¹	31	4	5,3,3	7	●	●	1	1	3ch	32x32	●	—	—	USB	48 RGZ	\$1.50	
	MSP430F5502	24	4 + 2 ¹	31	4	5,3,3	7	●	●	1	1	3ch	32x32	●	—	—	USB	48RGZ	\$1.55	
	MSP430F5503	32	4 + 2 ¹	31	4	5,3,3	7	●	●	1	1	3ch	32x32	●	—	—	USB	48RGZ	\$1.70	
	MSP430F5504	8	4 + 2 ¹	31	4	5,3,3	7	●	●	1	1	3ch	32x32	—	●	8ch/ADC10	—	USB	48RGZ, 48PT	\$1.60
	MSP430F5505	16	4 + 2 ¹	31	4	5,3,3	7	●	●	1	1	3ch	32x32	—	●	8ch/ADC10	—	USB	48RGZ	\$1.65
	MSP430F5506	24	4 + 2 ¹	31	4	5,3,3	7	●	●	1	1	3ch	32x32	—	●	8ch/ADC10	—	USB	48RGZ	\$1.80
	MSP430F5507	32	4 + 2 ¹	31	4	5,3,3	7	●	●	1	1	3ch	32x32	—	●	8ch/ADC10	—	USB	48RGZ	\$1.90
	MSP430F5508	16	4 + 2 ¹	47	4	5,3,3	7	●	●	2	2	3ch	32x32	●	●	12ch/ADC10	—	USB	48RGZ, 48PT, 64RGC, 80ZQE	\$1.75
	MSP430F5509	24	4 + 2 ¹	47	4	5,3,3	7	●	●	2	2	3ch	32x32	●	●	12ch/ADC10	—	USB	48RGZ, 48PT, 64RGC, 80ZQE	\$1.85
MSP430F5510	32	4 + 2 ¹	47	4	5,3,3	7	●	●	2	2	3ch	32x32	●	●	12ch/ADC10	—	USB	48 RGZ, 48PT, 64RGC, 80ZQE	\$1.95	

¹Prices are quoted in U.S. dollars and represent year 2012 suggested resale price. *Represents number of capture/compare registers per timer. ¹Additional 2K of SRAM available if USB is disabled

MSP430F5xx Series – Up to 25 MHz (continued)

Series	Part Number	Program (KB)	SRAM (KB)	I/O (max)	Timers			Watchdog Timer	PMM: BOR, SVS, SVM, LDO	USCI		DMA	MPY	Comp B	Temp Sensor	ADC Ch/Res	DAC	Additional Features	Package(s)	1 ku Price ¹
					Total	A	B			Ch A: UART/LIN/IrDA/SPI	Ch B: I ² C/SPI									
F55xx	MSP430F5513	32	4 + 2 [†]	47	4	5,3,3	7	●	●	2	2	3ch	32x32 [*]	●	—	—	—	USB	64RGC, 80ZQE	\$3.25
	MSP430F5514	64	4 + 2 [†]	47	4	5,3,3	7	●	●	2	2	3ch	32x32 [*]	●	—	—	—	USB	64RGC, 80ZQE	\$3.55
	MSP430F5515	64	4 + 2 [†]	63	4	5,3,3	7	●	●	2	2	3ch	32x32 [*]	●	—	—	—	USB	80PN	\$3.65
	MSP430F5517	96	6 + 2 [†]	63	4	5,3,3	7	●	●	2	2	3ch	32x32 [*]	●	—	—	—	USB	80PN	\$3.75
	MSP430F5519	128	8 + 2 [†]	63	4	5,3,3	7	●	●	2	2	3ch	32x32 [*]	●	—	—	—	USB	80PN	\$3.90
	MSP430F5521	32	6 + 2 [†]	63	4	5,3,3	7	●	●	2	2	3ch	32x32 [*]	●	●	16ch/ADC12 A	—	USB	80PN	\$3.35
	MSP430F5522	32	8 + 2 [†]	47	4	5,3,3	7	●	●	2	2	3ch	32x32 [*]	●	●	12ch/ADC12 A	—	USB	64RGC, 80ZQE	\$3.40
	MSP430F5524	64	4 + 2 [†]	47	4	5,3,3	7	●	●	2	2	3ch	32x32 [*]	●	●	12ch/ADC12 A	—	USB	64RGC, 80ZQE, 64YFF	\$3.55
	MSP430F5525	64	4 + 2 [†]	63	4	5,3,3	7	●	●	2	2	3ch	32x32 [*]	●	●	16ch/ADC12 A	—	USB	80PN	\$3.70
	MSP430F5526	96	6 + 2 [†]	47	4	5,3,3	7	●	●	2	2	3ch	32x32 [*]	●	●	12ch/ADC12 A	—	USB	64RGC, 80ZQE, 64YFF	\$3.80
	MSP430F5527	96	6 + 2 [†]	63	4	5,3,3	7	●	●	2	2	3ch	32x32 [*]	●	●	16ch/ADC12 A	—	USB	80PN	\$3.90
	MSP430F5528	128	8 + 2 [†]	47	4	5,3,3	7	●	●	2	2	3ch	32x32 [*]	●	●	12ch/ADC12 A	—	USB	64RGC, 80ZQE, 64YFF	\$3.95
MSP430F5529	128	8 + 2 [†]	63	4	5,3,3	7	●	●	2	2	3ch	32x32 [*]	●	●	16ch/ADC12 A	—	USB	80PN	\$4.00	
F663x	MSP430F5630	128	16 + 2 [†]	74	4	5,3,3	7	●	●	2	2	6ch	32x32 [*]	●	—	—	—	USB, Backup battery switch	100PZ, 113ZQW	\$4.65
	MSP430F5631	192	16 + 2 [†]	74	4	5,3,3	7	●	●	2	2	6ch	32x32 [*]	●	—	—	—	USB, Backup battery switch	100PZ, 113ZQW	\$5.20
	MSP430F5632	256	16 + 2 [†]	74	4	5,3,3	7	●	●	2	2	6ch	32x32 [*]	●	—	—	—	USB, Backup battery switch	100PZ, 113ZQW	\$5.75
	MSP430F5633	128	16 + 2 [†]	74	4	5,3,3	7	●	●	2	2	6ch	32x32 [*]	●	●	16ch/ADC12 A	—	USB, Backup battery switch	100PZ, 113ZQW	\$5.35
	MSP430F5634	192	16 + 2 [†]	74	4	5,3,3	7	●	●	2	2	6ch	32x32 [*]	●	●	16ch/ADC12 A	—	USB, Backup battery switch	100PZ, 113ZQW	\$5.70
	MSP430F5635	256	16 + 2 [†]	74	4	5,3,3	7	●	●	2	2	6ch	32x32 [*]	●	●	16ch/ADC12 A	—	USB, Backup battery switch	100PZ, 113ZQW	\$6.05
	MSP430F5636	128	16 + 2 [†]	74	4	5,3,3	7	●	●	2	2	6ch	32x32 [*]	●	●	16ch/ADC12 A	●	USB, Backup battery switch	100PZ, 113ZQW	\$6.20
	MSP430F5637	192	16 + 2 [†]	74	4	5,3,3	7	●	●	2	2	6ch	32x32 [*]	●	●	16ch/ADC12 A	●	USB, Backup battery switch	100PZ, 113ZQW	\$6.50
	MSP430F5638	256	16 + 2 [†]	74	4	5,3,3	7	●	●	2	2	6ch	32x32 [*]	●	●	16ch/DC12 A	●	USB, Backup battery switch	100PZ, 113ZQW	\$6.85

¹Prices are quoted in U.S. dollars and represent year 2012 suggested resale price. *Represents number of capture/compare registers per timer. [†]Additional 2K of SRAM available if USB is disabled

[‡]Supports 64 bit result length *New products are listed in red.*

MSP430F6xx Series - Up to 25 MHz with LCD

Series	Part Number	Flash (KB)	SRAM (KB)	I/O (max)	16-Bit Timers			Watchdog and RTC	PMM: BOR, SVS, SVM, LDO	USCI		DMA	MPY	Comp B	Temp Sensor	ADC Ch/Res	DAC	Additional Features	Packages	1 ku Price ¹
					Total	A [‡]	B [‡]			Ch A: UART/LIN/IrDA/SPI	Ch B: I ² C/SPI									
F663x	MSP430F6630	128	16 + 2 [†]	74	4	5,3,3	7	●	●	2	2	6ch	32x32	●	—	—	—	USB, LCD	100PZ, 113ZQW	\$5.85
	MSP430F6631	192	16 + 2 [†]	74	4	5,3,3	7	●	●	2	2	6ch	32x32	●	—	—	—	USB, LCD	100PZ, 113ZQW	\$6.15
	MSP430F6632	256	16 + 2 [†]	74	4	5,3,3	7	●	●	2	2	6ch	32x32	●	—	—	—	USB, LCD	100PZ, 113ZQW	\$6.50
	MSP430F6633	128	16 + 2 [†]	74	4	5,3,3	7	●	●	2	2	6ch	32x32	●	●	16ch/ADC12 A	—	USB, LCD	100PZ, 113ZQW	\$5.95
	MSP430F6634	192	16 + 2 [†]	74	4	5,3,3	7	●	●	2	2	6ch	32x32	●	●	16ch/ADC12 A	—	USB, LCD	100PZ, 113ZQW	\$6.30
	MSP430F6635	256	16 + 2 [†]	74	4	5,3,3	7	●	●	2	2	6ch	32x32	●	●	16ch/ADC12 A	—	USB, LCD	100PZ, 113ZQW	\$6.60
	MSP430F6636	128	16 + 2 [†]	74	4	5,3,3	7	●	●	2	2	6ch	32x32	●	●	16ch/ADC12 A	●	USB, LCD	100PZ, 113ZQW	\$6.30
	MSP430F6637	192	16 + 2 [†]	74	4	5,3,3	7	●	●	2	2	6ch	32x32	●	●	16ch/ADC12 A	●	USB, LCD	100PZ, 113ZQW	\$6.60
	MSP430F6638	256	16 + 2 [†]	74	4	5,3,3	7	●	●	2	2	6ch	32x32	●	●	16ch/ADC12 A	●	USB, LCD	100PZ, 113ZQW	\$6.95
F643x	MSP430F6433	128	10	74	4	5,3,3	7	●	●	2	2	6ch	32x32	●	●	16ch/ADC12 A	—	LCD	100PZ, 113ZQW	\$5.00
	MSP430F6434	192	18	74	4	5,3,3	7	●	●	2	2	6ch	32x32	●	●	16ch/ADC12 A	—	LCD	100PZ, 113ZQW	\$5.25
	MSP430F6435	256	18	74	4	5,3,3	7	●	●	2	2	6ch	32x32	●	●	16ch/ADC12 A	—	LCD	100PZ, 113ZQW	\$5.50
	MSP430F6436	128	18	74	4	5,3,3	7	●	●	2	2	6ch	32x32	●	●	16ch/ADC12 A	●	LCD	100PZ, 113ZQW	\$5.75
	MSP430F6437	192	18	74	4	5,3,3	7	●	●	2	2	6ch	32x32	●	●	16ch/ADC12 A	●	LCD	100PZ, 113ZQW	\$6.05
	MSP430F6438	256	18	74	4	5,3,3	7	●	●	2	2	6ch	32x32	●	●	16ch/ADC12 A	●	LCD	100PZ, 113ZQW	\$6.40
F643x	MSP430F6720	16	1	72	4	2,2,2,3	—	●	●	3	1	3ch	32x32	—	●	(2) SD24, 8ch/ADC10A	—	Backup AUX Supply	100PZ, 80PN	\$2.00
	MSP430F6721	32	2	72	4	2,2,2,3	—	●	●	3	1	3ch	32x32	—	●	(2) SD24, 8ch/ADC10A	—	Backup AUX Supply	100PZ, 80PN	\$2.10
	MSP430F6723	64	4	72	4	2,2,2,3	—	●	●	3	1	3ch	32x32	—	●	(2) SD24, 8ch/ADC10A	—	Backup AUX Supply	100PZ, 80PN	\$2.30
	MSP430F6724	96	4	72	4	2,2,2,3	—	●	●	3	1	3ch	32x32	—	●	(2) SD24, 8ch/ADC10A	—	Backup AUX Supply	100PZ, 80PN	\$2.45
	MSP430F6725	128	4	72	4	2,2,2,3	—	●	●	3	1	3ch	32x32	—	●	(2) SD24, 8ch/ADC10A	—	Backup AUX Supply	100PZ, 80PN	\$2.60
	MSP430F6726	128	8	72	4	2,2,2,3	—	●	●	3	1	3ch	32x32	—	●	(2) SD24, 8ch/ADC10A	—	Backup AUX Supply	100PZ, 80PN	\$2.70
	MSP430F6730	16	1	72	4	2,2,2,3	—	●	●	3	1	3ch	32x32	—	●	(3) SD24, 8ch/ADC10A	—	Backup AUX Supply	100PZ, 80PN	\$2.45
	MSP430F6731	32	2	72	4	2,2,2,3	—	●	●	3	1	3ch	32x32	—	●	(3) SD24, 8ch/ADC10A	—	Backup AUX Supply	100PZ, 80PN	\$2.55
	MSP430F6733	64	4	72	4	2,2,2,3	—	●	●	3	1	3ch	32x32	—	●	(3) SD24, 8ch/ADC10A	—	Backup AUX Supply	100PZ, 80PN	\$2.75
	MSP430F6734	96	4	72	4	2,2,2,3	—	●	●	3	1	3ch	32x32	—	●	(3) SD24, 8ch/ADC10A	—	Backup AUX Supply	100PZ, 80PN	\$3.00
	MSP430F6735	128	4	72	4	2,2,2,3	—	●	●	3	1	3ch	32x32	—	●	(3) SD24, 8ch/ADC10A	—	Backup AUX Supply	100PZ, 80PN	\$3.15
MSP430F6736	128	8	72	4	2,2,2,3	—	●	●	3	1	3ch	32x32	—	●	(3) SD24, 8ch/ADC10A	—	Backup AUX Supply	100PZ, 80PN	\$3.25	

¹Prices are quoted in U.S. dollars and represent year 2012 suggested resale price. *Represents number of capture/compare register per timer.

[†]Additional 2K of SRAM available if USB is disabled.

CC430 (Sub-1GHz RF + MSP430™ Microcontroller) Series – Up to 20 MHz

Series	Part Number	Flash (KB)	SRAM (KB)	I/O (max)	16-Bit Timers			Watchdog and RTC	PMM: BOR, SVS, SVM, LDO	USCI		DMA	MPY	Comp B	Temp Sensor	ADC Ch/Res	Additional Features	Package(s)	1ku Price ¹	Common Features
					Total	A*	B*			Ch A: UART/LIN/IrDA/SPI	Ch B: I ² C/SPI									
F51xx	CC430F5133	8	2	30	2	5	3	●	●	1	1	3ch	32x32	●	●	6ch/ADC12	—	48RGZ	\$4.15	- AES HW Encryption
	CC430F5135	16	2	30	2	5	3	●	●	1	1	3ch	32x32	●	●	6ch/ADC12	—	48RGZ	\$4.30	- Max RF Data Rate 500 kbps
	CC430F5137	32	4	30	2	5	3	●	●	1	1	3ch	32x32	●	●	6ch/ADC12	—	48RGZ	\$5.00	- Best Sensitivity: 110 dBm ¹
F61xx	CC430F6125	16	2	44	2	5	3	●	●	1	1	3ch	32x32	●	—	—	96seg LCD	64RGC	\$4.35	- Frequency Ranges: 300-348 MHz
	CC430F6126	32	2	44	2	5	3	●	●	1	1	3ch	32x32	●	—	—	96seg LCD	64RGC	\$4.60	- Frequency Ranges: 389-464 MHz
	CC430F6127	32	4	44	2	5	3	●	●	1	1	3ch	32x32	●	—	—	96seg LCD	64RGC	\$5.05	- Frequency Ranges: 389-464 MHz
	CC430F6135	16	2	44	2	5	3	●	●	1	1	3ch	32x32	●	●	8ch/ADC12	96seg LCD	64RGC	\$4.65	- Frequency Ranges: 779-929 MHz
	CC430F6137	32	4	44	2	5	3	●	●	1	1	3ch	32x32	●	●	8ch/ADC12	96seg LCD	64RGC	\$5.35	- Frequency Ranges: 779-929 MHz

¹Prices are quoted in U.S. dollars and represent year 2012 suggested resale price. *Represents number of capture/compare register per timer. ¹At 1.2 kbaud, 868 MHz, 1% packet error rate.

Automotive and Enhanced Performance

Series	Part Number	Frequency (MHz)	Flash (KB)	SRAM (B)	GPIO	16-bit Timers	Watchdog	Brown Out Reset	USI (I ² C/SPI)	DMA	MPY	Comp	Temp Sensor	ADC	Additional Features	Pin/Package
Auto and EP	MSP430F2232-Q1	16	8	512	32	2	●	●	2	—	—	—	●	12ch/ADC10	—	40RHA, 38DA
	MSP430F2234-Q1	16	8	512	32	2	●	●	2	—	—	—	●	12ch/ADC10	(2) Op Amp	38DA, 40RHA
	MSP430F2252-Q1	16	16	512	32	2	●	●	2	—	—	—	●	12ch/ADC10	—	38DA, 40RHA
	MSP430F2254-Q1	16	16	512	32	2	●	●	2	—	—	—	●	12ch/ADC10	(2) Op Amp	38DA, 40RHA
	MSP430F2272-Q1	16	32	1024	32	2	●	●	2	—	—	—	●	12ch/ADC10	—	38DA, 40RHA
	MSP430F2274-Q1	16	32	1024	32	2	●	●	2	—	—	—	●	12ch/ADC10	(2) Op Amp	38DA, 40RHA
	MSP430G2001-Q1	16	0.5	128	10	1	●	●	1	—	—	—	—	—	—	14PW, 16RSA
	MSP430G2101-Q1	16	1	128	10	1	●	●	1	—	—	●	—	—	Cap Touch IO	14PW, 16RSA
	MSP430G2111-Q1	16	1	128	10	1	●	●	1	—	—	●	—	Slope	Cap Touch IO	14PW, 16RSA
	MSP430G2121-Q1	16	1	128	10	1	●	●	1	—	—	●	—	—	Cap Touch IO	14PW, 16RSA
	MSP430G2131-Q1	16	1	128	10	1	●	●	1	—	—	●	—	8ch/ADC10	Cap Touch IO	14PW, 16RSA
	MSP430G2201-Q1	16	2	128	10	1	●	●	1	—	—	●	—	—	Cap Touch IO	14PW, 16RSA
	MSP430G2211-Q1	16	2	128	10	1	●	●	1	—	—	●	—	Slope	Cap Touch IO	14QFN, 14PW, 16RSA
	MSP430G2221-Q1	16	2	128	10	1	●	●	1	—	—	●	—	—	Cap Touch IO	14PW, 16RSA
	MSP430G2231-Q1	16	2	128	10	1	●	●	1	●	16x16	●	●	8ch/ADC10	Cap Touch IO	14PW, 16RSA
	MSP430F2619S-HT	16	60	4096	48	2	●	●	2	—	—	●	●	8ch/ADC12	DAC12	64PM
	MSP430F2013-EP	16	2	128	10	1	●	●	1	—	—	●	●	4ch/SD16	—	16RSA
	MSP430F2274-EP	16	32	1024	32	2	●	●	2	—	—	●	●	12ch/ADC12	(2) Op Amp	38DA, 40RHA
MSP430F249-EP	16	60	2048	48	2	●	●	2	—	16x16	●	●	8ch/ADC12	—	64PM	
MSP430F2618-EP	16	116	8192	48	2	●	●	2	●	16x16	●	●	8ch/ADC12	DAC12	113BGA MICROSTAR JUNIOR	

¹Prices are quoted in U.S. dollars and represent year 2012 suggested resale price. *New products are listed in red. Preview products are listed in blue.*

MSP430™ FRAM Series – Up to 24 MHz

Series	Part Number	FRAM (KB)	SRAM (B)	CPU Speed (MHz)	I/O (max)	Timers			Watchdog and RTC	PMM: BOR, SVS, SVM, LDO	USCI		DMA	MPY	Comp B	Temp Sensor	ADC Ch/Res	Additional Features	Pin/Package	1 ku Price
						Total	A*	B*			Ch A: UART/LIN/IrDA/SPI	Ch B: I ² C/SPI								
FR57x	MSP430FR5720	4	512	8	33	3	3,3	3,3	●	●	1	1	●	●	●	●	10ch/ADC10B	MPU	24RGE, 28PW	\$1.75
	MSP430FR5721	4	512	8	33	5	3,3	3,3,3	●	●	2	1	●	●	●	●	14ch/ADC10B	MPU	38DA, 40RHA	\$1.80
	MSP430FR5722	8	1024	8	33	3	3,3	3,3	●	●	1	1	●	●	●	●	—	MPU	24RGE, 28PW	\$1.85
	MSP430FR5723	8	1024	8	33	5	3,3	3,3,3	●	●	2	1	●	●	●	●	—	MPU	38DA, 40RHA	\$2.00
	MSP430FR5724	8	1024	8	33	3	3,3	3,3	●	●	1	1	●	●	●	●	10ch/ADC10B	MPU	24RGE, 28PW	\$1.95
	MSP430FR5725	8	1024	8	33	5	3,3	3,3,3	●	●	2	1	●	●	●	●	14ch/ADC10B	MPU	38DA, 40RHA	\$2.15
	MSP430FR5726	16	1024	8	33	3	3,3	3,3	●	●	1	1	●	●	●	●	—	MPU	24RGE, 28PW	\$2.00
	MSP430FR5727	16	1024	8	33	5	3,3	3,3,3	●	●	2	1	●	●	●	●	—	MPU	38DA, 40RHA	\$2.20
	MSP430FR5728	16	1024	8	33	3	3,3	3,3	●	●	1	1	●	●	●	●	10ch/ADC10B	MPU	24RGE, 28PW	\$2.15
	MSP430FR5729	16	1024	8	33	5	3,3	3,3,3	●	●	2	1	●	●	●	●	14ch/ADC10B	MPU	38DA, 40RHA	\$2.35
FR67x	MSP430FR5730	16	512	24	33	3	3,3	3,3	●	●	1	1	●	●	●	●	10ch/ADC10B	MPU	24RGE, 28PW	\$1.90
	MSP430FR5731	4	512	24	33	5	3,3	3,3,3	●	●	2	1	●	●	●	●	14ch/ADC10B	MPU	38DA, 40RHA	\$1.95
	MSP430FR5732	4	1024	24	33	3	3,3	3,3	●	●	1	1	●	●	●	●	—	MPU	24RGE, 28PW	\$2.00
	MSP430FR5733	8	1024	24	33	5	3,3	3,3,3	●	●	2	1	●	●	●	●	—	MPU	38DA, 40RHA	\$2.05
	MSP430FR5734	8	1024	24	33	3	3,3	3,3	●	●	1	1	●	●	●	●	10ch/ADC10B	MPU	24RGE, 28PW	\$2.10
	MSP430FR5735	8	1024	24	33	5	3,3	3,3,3	●	●	2	1	●	●	●	●	14ch/ADC10B	MPU	38DA, 40RHA	\$2.20
	MSP430FR5736	16	1024	24	33	3	3,3	3,3	●	●	1	1	●	●	●	●	—	MPU	24RGE, 28PW	\$2.25
	MSP430FR5737	16	1024	24	33	5	3,3	3,3,3	●	●	2	1	●	●	●	●	—	MPU	38DA, 40RHA	\$2.30
	MSP430FR5738	16	1024	24	33	3	3,3	3,3	●	●	1	1	●	●	●	●	10ch/ADC10B	MPU	24RGE, 28PW	\$2.35
	MSP430FR5739	16	1024	24	33	5	3,3	3,3,3	●	●	2	1	●	●	●	●	14ch/ADC10B	MPU	38DA, 40RHA	\$2.45

¹Prices are quoted in U.S. dollars and represent year 2012 suggested resale price. *Represents number of capture/compare registers per timer.

Ultra-Low Power MSP430™ MCU Selected Package Options

14-pin TSSOP (PW) 	14-pin N (DIP) 	16-pin RSA (QFN) 	20-pin DVG (TVSOP) 	20-pin TSSOP (PW) 	20-pin SOIC (DW)
20-pin N (PDIP) 	24-pin RGE (QFN) 	28-pin DW (SOIC) 	28-pin TSSOP (PW) 	32-pin RTV (QFN) 	32-pin RHB (QFN)
38-pin DA (TSSOP) 	40-pin RHA (QFN) 	40-pin RSB (QFN) 	48-pin RGZ (QFN) 	48-pin DL (SSOP) 	48-pin PT (LQFP)
64-pin RGC, RTD (QFN) 	64-pin PM, PAG (LQFP/TQFP) 	80-pin ZQE (BGA) 	80-pin PN (LQFP) 	100-pin PZ (LQFP) 	113-pin ZQW (BGA)

Die-Size BGA Packages

49-pin YFF (DSBGA) MSP430F22xx 	49-pin YFF (DSBGA) MSP430F23xx 	64-pin YFF (DSBGA) MSP430F55xx
---	---	---

All dimensions are nominal values in millimeters.

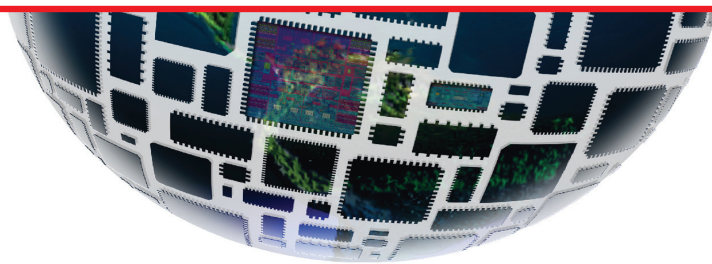

TI University Program Technology for Tomorrow's Innovators

The TI University Program is dedicated to support educators, researchers and students with assistance integrating TI technology into course curricula, senior design and research projects.



University Zone Blog
Connect with TI's university experts and follow the latest trends in engineering academia.
www.ti.com/universityblog

Learn more about the program, sample free Embedded ICs, discounted development kits, and get support with your senior design projects or curriculum development.

www.ti.com/university

Embedded Processing Portfolio

MCU		Software, Tools, Kits & Boards	DSP and ARM® MPU		
Microcontroller (MCU) Portfolio at-a-glance		ARM® Portfolio at-a-glance	Digital Signal Processor (DSP) Portfolio at-a-glance		
<p>16-bit Ultra-Low Power and Value Line MCUs</p> <p>MSP™ MCU</p> <p>– MSP430 MCU</p> <p>Measurement, sensing, general purpose, consumer, medical</p>	<p>32-bit Real-Time MCUs</p> <p>C2000™ MCU</p> <p>– Delfino, Piccolo single-core MCU</p> <p>– Concerto C28x+ ARM Cortex™-M</p> <p>Motor control, digital power, lighting, renewable energy</p>	<p>32-bit MCUs</p> <p>Stellaris® ARM MCU and Hercules™ Safety ARM MCU</p> <p>– ARM Cortex™-M</p> <p>– ARM Cortex™-R</p> <p>Motion control, human machine interface, industrial automation, smart grid, safety, transportation, industrial and medical</p>	<p>32-bit Microprocessors</p> <p>Sitara™ ARM MPU</p> <p>– ARM Cortex-A8</p> <p>– ARM9™</p> <p>Industrial automation, point-of-service, human machine interface, portable navigation</p>	<p>16/32-bit Single-core DSPs</p> <p>C6000™ and C5000™ single-core DSP</p> <p>– C6000 high performance fixed/floating-point DSP</p> <p>– C5000 ultra-low power fixed-point DSP</p> <p>Connected audio/voice, video, fingerprint biometrics, portable medical, sensors</p>	<p>32-bit Multicore DSPs</p> <p>C6000™ -based multicore DSP</p> <p>Fixed/floating-point:</p> <p>– DSP + ARM</p> <p>– C66x multicore DSP</p> <p>– DaVinci video processors</p> <p>High performance real-time computing, video security and analytics, video communications, multimedia infrastructure</p>

TI Worldwide Technical Support

Internet

TI Semiconductor Product Information Center Home Page
support.ti.com

TI E2E Community Home Page
e2e.ti.com

Product Information Centers

Americas	Phone	+1(972) 644-5580
Brazil	Phone	0800-891-2616
Mexico	Phone	0800-670-7544
	Fax	+1(972) 927-6377
	Internet/Email	support.ti.com/sc/pic/americas.htm

Europe, Middle East, and Africa

Phone		
European Free Call	00800-ASK-TEXAS (00800 275 83927)	
International	+49 (0) 8161 80 2121	
Russian Support	+7 (4) 95 98 10 701	
Note: The European Free Call (Toll Free) number is not active in all countries. If you have technical difficulty calling the free call number, please use the international number above.		
Fax	+49 (0) 8161 80 2045	
Internet	support.ti.com/sc/pic/euro.htm	

Japan

Phone	Domestic	0120-92-3326
Fax	International	+81-3-3344-5317
	Domestic	0120-81-0036
Internet/Email	International	support.ti.com/sc/pic/japan.htm
	Domestic	www.tij.co.jp/pic

Asia

Phone		
International		+91-80-41381665
Domestic		Toll-Free Number
Australia		1-800-999-084
China		800-820-8682
Hong Kong		800-96-5941
India		1-800-425-7888
Indonesia		001-803-8861-1006
Korea		080-551-2804
Malaysia		1-800-80-3973
New Zealand		0800-446-934
Philippines		1-800-765-7404
Singapore		800-886-1028
Taiwan		0800-006800
Thailand		001-800-886-0010
Fax	+886-2-2378-6808	
Email	tiasia@ti.com	
	ti-china@ti.com	
Internet	support.ti.com/sc/pic/asia.htm	

Important Notice: The products and services of Texas Instruments Incorporated and its subsidiaries described herein are sold subject to TI's standard terms and conditions of sale. Customers are advised to obtain the most current and complete information about TI products and services before placing orders. TI assumes no liability for applications assistance, customer's applications or product designs, software performance, or infringement of patents. The publication of information regarding any other company's products or services does not constitute TI's approval, warranty or endorsement thereof.

B121709

The platform bar, MSP430, eZ430-Chronos, SimplicTI, Code Composer Studio, Grace, SmartRF and C2000 are trademarks of Texas Instruments. The *Bluetooth* word mark and logos are owned by the Bluetooth SIG, Inc., and any use of such marks by Texas Instruments is under license. ARM is a registered trademark of ARM Limited. WiMax is a trademark of the WiMax Forum. ZigBee is a registered trademark of the ZigBee Alliance. All other trademarks are the property of their respective owners.

IMPORTANT NOTICE

Texas Instruments Incorporated and its subsidiaries (TI) reserve the right to make corrections, enhancements, improvements and other changes to its semiconductor products and services per JESD46, latest issue, and to discontinue any product or service per JESD48, latest issue. Buyers should obtain the latest relevant information before placing orders and should verify that such information is current and complete. All semiconductor products (also referred to herein as "components") are sold subject to TI's terms and conditions of sale supplied at the time of order acknowledgment.

TI warrants performance of its components to the specifications applicable at the time of sale, in accordance with the warranty in TI's terms and conditions of sale of semiconductor products. Testing and other quality control techniques are used to the extent TI deems necessary to support this warranty. Except where mandated by applicable law, testing of all parameters of each component is not necessarily performed.

TI assumes no liability for applications assistance or the design of Buyers' products. Buyers are responsible for their products and applications using TI components. To minimize the risks associated with Buyers' products and applications, Buyers should provide adequate design and operating safeguards.

TI does not warrant or represent that any license, either express or implied, is granted under any patent right, copyright, mask work right, or other intellectual property right relating to any combination, machine, or process in which TI components or services are used. Information published by TI regarding third-party products or services does not constitute a license to use such products or services or a warranty or endorsement thereof. Use of such information may require a license from a third party under the patents or other intellectual property of the third party, or a license from TI under the patents or other intellectual property of TI.

Reproduction of significant portions of TI information in TI data books or data sheets is permissible only if reproduction is without alteration and is accompanied by all associated warranties, conditions, limitations, and notices. TI is not responsible or liable for such altered documentation. Information of third parties may be subject to additional restrictions.

Resale of TI components or services with statements different from or beyond the parameters stated by TI for that component or service voids all express and any implied warranties for the associated TI component or service and is an unfair and deceptive business practice. TI is not responsible or liable for any such statements.

Buyer acknowledges and agrees that it is solely responsible for compliance with all legal, regulatory and safety-related requirements concerning its products, and any use of TI components in its applications, notwithstanding any applications-related information or support that may be provided by TI. Buyer represents and agrees that it has all the necessary expertise to create and implement safeguards which anticipate dangerous consequences of failures, monitor failures and their consequences, lessen the likelihood of failures that might cause harm and take appropriate remedial actions. Buyer will fully indemnify TI and its representatives against any damages arising out of the use of any TI components in safety-critical applications.

In some cases, TI components may be promoted specifically to facilitate safety-related applications. With such components, TI's goal is to help enable customers to design and create their own end-product solutions that meet applicable functional safety standards and requirements. Nonetheless, such components are subject to these terms.

No TI components are authorized for use in FDA Class III (or similar life-critical medical equipment) unless authorized officers of the parties have executed a special agreement specifically governing such use.

Only those TI components which TI has specifically designated as military grade or "enhanced plastic" are designed and intended for use in military/aerospace applications or environments. Buyer acknowledges and agrees that any military or aerospace use of TI components which have **not** been so designated is solely at the Buyer's risk, and that Buyer is solely responsible for compliance with all legal and regulatory requirements in connection with such use.

TI has specifically designated certain components as meeting ISO/TS16949 requirements, mainly for automotive use. In any case of use of non-designated products, TI will not be responsible for any failure to meet ISO/TS16949.

Products

Audio	www.ti.com/audio
Amplifiers	amplifier.ti.com
Data Converters	dataconverter.ti.com
DLP® Products	www.dlp.com
DSP	dsp.ti.com
Clocks and Timers	www.ti.com/clocks
Interface	interface.ti.com
Logic	logic.ti.com
Power Mgmt	power.ti.com
Microcontrollers	microcontroller.ti.com
RFID	www.ti-rfid.com
OMAP Applications Processors	www.ti.com/omap
Wireless Connectivity	www.ti.com/wirelessconnectivity

Applications

Automotive and Transportation	www.ti.com/automotive
Communications and Telecom	www.ti.com/communications
Computers and Peripherals	www.ti.com/computers
Consumer Electronics	www.ti.com/consumer-apps
Energy and Lighting	www.ti.com/energy
Industrial	www.ti.com/industrial
Medical	www.ti.com/medical
Security	www.ti.com/security
Space, Avionics and Defense	www.ti.com/space-avionics-defense
Video and Imaging	www.ti.com/video

TI E2E Community

e2e.ti.com